

INTER - UNIVERSITY ACCELERATOR CENTRE

(An Autonomous Centre of UGC)

Aruna Asaf Ali Marg, New Delhi - 110067

NOTICE INVITING E - TENDER

Tender Number : IUAC/NIT/24/RA/2021-22

Dated : 14/10/2021

Inter - University Accelerator Centre (IUAC) invites online bids on behalf of the Director IUAC, New Delhi through e-procurement Portal under two bid system, viz., Technical and Financial bids, from eligible / experienced parties for the work/supply of FABRICATION, ASSEMBLING, TESTING & SUPPLY OF TWO (2) NOS. OF SPIRAL BUNCHER WORKING UNDER HIGH VACUUM AS PER DRAWINGS & SPECIFICATIONS.

Tender Documents may be downloaded from Central Public Procurement (CPP) Portal free of cost <https://eprocure.gov.in/eprocure/app>. Aspiring Bidders who have not enrolled / registered in e-procurement portal should enroll / register before participating through the website <https://eprocure.gov.in/eprocure/app>. Bids should be submitted online only at website: <https://eprocure.gov.in/eprocure/app>. Tenderers / Contractors / Bidders are advised to follow the instructions provided in the e-procurement portal. Bid documents may be scanned with 100 dpi with black and white option which helps in reducing size of the scanned documents.

Only bids received through e-procurement portal will be considered for opening. Bids not covering full scope of work/supply of the products/goods will be rejected and only complete bids will be considered. IUAC reserves the right to accept / reject any / all tenders in part / full without assigning any reasons whatsoever, and the decision of IUAC in this regard will be binding on all the bidders.

As per notification no. F/9/4/2020-PPD dated 12.11.2020 issued by Ministry of Finance, Department of Expenditure, Govt. of India, bidders have to submit “Bid Security Declaration” accepting that if they withdraw or modify their bids during period of validity etc., they will be suspended for the time specified in the tender documents”. Tenderers registered with MSME/NSIC (the unit being registered for the item/work tendered) are required to upload copy of valid registration certificate in the website <https://eprocure.gov.in/eprocure/app> along with technical bid.

Bidders are advised to note that they should necessarily submit their financial bids in the format provided and no other format is acceptable. If the price bid has been given as a standard .XLS BOQ Format with the tender document, then the same is to be downloaded and to be filled and submitted online without modifying the format. **If the BOQ file is found to be modified by the bidder, the bid will be rejected.** Any Corrigendum / Amendments in respect of above tender shall be issued on website <https://eprocure.gov.in> and www.iuac.res.in only. Bidders should take into account any corrigendum published on the tender document before submitting their bids.

The Director, IUAC reserves the right to accept/reject any/all tenders in part/full without assigning any reasons thereof.

E - TENDER DOCUMENT

Name of Work / Supply	FABRICATION, ASSEMBLING, TESTING & SUPPLY OF TWO (2) NOs. OF SPIRAL BUNCHERS WORKING UNDER HIGH VACUUM AS PER DRAWINGS & SPECIFICATIONS
Tender Number	IUAC/NIT/24/RA/2021-22
Tender Value/Estimated only	Rs.70,00,000/- (Rupees Seventy Lakhs Only)
Tender Document Fee	NIL
Bid Submission End Date and Time (Part - A and Part - B)	08/11/2021, at 3:00 P.M.
Technical Bid Opening Date (Part - A)	09/11/2021, at 3:30 P.M.
Price Bid Opening Date (Part - B)	To be intimated, later on, to the technically qualified bidders
Contact Person	Administrative Officer (S&P) e-mail: iuacstores@gmail.com Phone: 011-24126018, 24126022.

TENDER FORM

To

The Director
IUAC,
Aruna Asaf Ali Marg,
New Delhi 110067

Dear Sir,

I/We have read and examined the following Tender Documents relating to the supply of FABRICATION, ASSEMBLING, TESTING & SUPPLY OF TWO (2) NOS. OF SPIRAL BUNCHERS WORKING UNDER HIGH VACUUM AS PER DRAWINGS & SPECIFICATIONS.

1. Registration process on CPP portal for online bidding, searching for tender documents, preparation of bids, submission of bids & assistance to bidders
2. Instructions for Online Bid Submission
3. Special Instructions to Bidders for Registration with Competent Authority
4. Scope of work
5. General Terms & Conditions of Contract
6. Special Terms and conditions of Contract
7. Annexures A to F
8. Price Bid

I/We hereby offer to execute the work complete in all respects specified in the underwritten Memorandum within the time specified therein, at the rates specified in the Price Bid and in accordance with the specifications and instruction in writing referred to in the condition of tender.

Tenderers Signature and Seal

REGISTRATION PROCESS ON CPP PORTAL FOR ONLINE BIDDING

1. Bidders are required to enroll on the e-Procurement module of the Central Public Procurement Portal (URL: <https://eprocure.gov.in/eprocure/app>) by clicking on the link “**Online Bidder Enrolment**” on the CPP Portal which is free of charge.
Bidder who registered already may skip the registration process and login to site through their user ID/Password
2. As part of the enrolment process, the bidders will be required to choose a unique username and assign a password for their accounts.
3. Bidders are advised to register their valid email address and mobile numbers as part of the registration process. These would be used for any communication from the CPP Portal.
4. Upon enrolment, the bidders will be required to register their valid Digital Signature Certificate (Class II or Class III Certificates with signing key usage) issued by any Certifying Authority recognized by CCA India (e.g. Sify / nCode / eMudhra/ Nic etc.), with their profile.
5. Only one valid DSC should be registered by a bidder. Please note that the bidders are responsible to ensure that they do not lend their DSC’s to others which may lead to misuse.
6. Bidder then logs in to the site through the secured log-in by entering their user ID / password and the password of the DSC / e-Token.

SEARCHING FOR TENDER DOCUMENTS

- 1 There are various search options built in the CPP Portal, to facilitate bidders to search active tenders by several parameters. These parameters could include Tender ID, Organization Name, Location, Date, Value, etc. There is also an option of advanced search for tenders, wherein the bidders may combine a number of search parameters such as Organization Name, Form of Contract, Location, Date, Other keywords etc. to search for a tender published on the CPP Portal.
- 2 Once the bidders have selected the tenders they are interested in, they may download the required documents / tender schedules. These tenders can be moved to the respective ‘My Tenders’ folder. This would enable the CPP Portal to intimate the bidders through SMS / e-mail in case there is any corrigendum issued to the tender document.
- 3 The bidder should make a note of the unique Tender ID assigned to each tender, in case they want to obtain any clarification / help from the Helpdesk.

PREPARATION OF BIDS

- 1 Please go through the tender advertisement and the tender document carefully to understand the documents required to be submitted as part of the bid. Please note the number of covers in which the bid documents have to be submitted, the number of documents - including the names and content of each of the document that need to be submitted. Any deviations from these may lead to rejection of the bid.
- 2 Bidder, in advance, should get ready the bid documents to be submitted as indicated in the tender document / schedule and generally, they can be in PDF / XLS / RAR / DWF/JPG formats. Bid documents may be scanned with 100 dpi with black and white option which helps in reducing size of the scanned document.
- 3 To avoid the time and effort required in uploading the same set of standard documents which are required to be submitted as a part of every bid, a provision of uploading such standard documents (e.g. PAN card copy, GST Certificate etc.) has been provided to the bidders. Bidders can use “My Space” or "Other Important Documents" area available to them to upload such documents. These documents may be directly submitted from the “My Space” area while submitting a bid, and need not be uploaded again and again. This will lead to a reduction in the time required for bid submission process.
Note: Bidder should take into account any corrigendum published on the tender document before submitting their bids.

INSTRUCTIONS FOR SUBMISSION OF BIDS

1. The tender documents are available on our website www.iuac.res.in & www.eprocure.gov.in.
2. Tender documents may be downloaded from IUAC’s website www.iuac.res.in and CPPP site <https://eprocure.gov.in/eprocure/app> as per the schedule as given in the tender document.
3. The tender shall be submitted online in two parts, viz., Technical bid and Financial (Price Bid) bid.
4. The offers submitted by hand/Post/Fax/email shall not be considered. No correspondence will be entertained in this matter.
5. All the pages of bid being submitted must be sequentially numbered by the bidder irrespective of nature and content of the documents before uploading.
6. The bidders are required to submit soft copies of their bids electronically on the CPP Portal, using valid Digital Signature Certificates. The instructions given below are meant to assist the bidders in

registering on the CPP Portal, prepare their bids in accordance with the requirements and submitting their bids online on the CPP Portal.

7. Bidder should log into the site well in advance for bid submission so that they can upload the bid in time i.e. on or before the bid submission time. Bidder will be responsible for any delay due to other issues.
8. The bidder has to digitally sign and upload the required bid documents one by one as indicated in the tender document.
9. Bidders are requested to note that they should necessarily submit their financial (Price Bid) bids in the format provided and no other format is acceptable. If the price bid has been given as a standard BOQ format with the tender document, then the same is to be downloaded and to be filled by all the bidders. Bidders are required to download the BOQ file, open it and complete the white colored (unprotected) cells with their respective financial quotes and other details (such as name of the bidder). No other cells should be changed. Once the details have been completed, the bidder should save it and submit it online, without changing the filename. If the BoQ file is found to be modified by the bidder, the bid will be rejected.
10. The server time (which is displayed on the bidders' dashboard) will be considered as the standard time for referencing the deadlines for submission of the bids by the bidders, opening of bids etc. The bidders should follow this time during bid submission.
11. All the documents being submitted by the bidders would be encrypted using PKI encryption techniques to ensure the secrecy of the data. The data entered cannot be viewed by unauthorized persons until the time of bid opening. The confidentiality of the bids is maintained using the secured Socket Layer 128 bit encryption technology. Data storage encryption of sensitive fields is done. Any bid document that is uploaded to the server is subjected to symmetric encryption using a system generated symmetric key. Further this key is subjected to asymmetric encryption using buyers/bid opener's public keys. Overall, the uploaded tender documents become readable only after the tender opening by the authorized bid openers.
12. The uploaded tender documents become readable only after the tender opening by the authorized bid openers.
13. Upon the successful and timely submission of bids (i.e. after Clicking "Freeze Bid Submission" in the portal), the portal will give a successful bid submission message & a bid summary will be displayed with the bid no. and the date & time of submission of the bid with all other relevant details.

14. The bid summary has to be printed and kept as an acknowledgment of the submission of the bid. This acknowledgment may be used as an entry pass for any bid opening meetings.
15. Not more than one tender shall be submitted by one contractor or contractors having business relationship. Under no circumstance will father and his son(s) or other close relations who have business relationship with one another (i.e. when one or more partner(s)/director(s) are common) be allowed to tender for the same contract as separate competitors. A breach of this condition will render the tenders of both parties liable to rejection.
16. The bidders are advised to visit CPPP website <https://eprocure.gov.in/eprocure/app> at least 3 days prior to closing date of submission of tender for any corrigendum / addendum/ amendment.
17. Bids will be opened as per date/time as mentioned in the **Tender Document**. After online opening and evaluation of technical bids, the results of their qualification as well Price-Bid opening will be intimated.
18. Submission of a tender by a tenderer implies that he has read all the stipulations contained in this tender document and has acquainted him of the nature, scope and specifications of the items to be followed.
19. The tenderer shall submit all documents after duly filling the same in all respects. Tenders which are found to be vague or incomplete shall be rejected summarily.
20. Tenders shall be submitted ON-LINE, it shall be signed by one, who has been authorized by the board of director /director / manufacture/ firm owner /their authorized agents through a resolution/ authority letter. Copy of the resolution/ authority letter in favor of the person signing must accompany the tender.
21. Tenders containing erasures and alterations of the tender documents are liable to be rejected unless these are authenticated by the person signing the Tender Documents.

22. **Code of Integrity for Public Procurement**

IUAC requires that the bidders, suppliers and contractors observe the highest standard of ethics during the procurement and execution of such contracts. In pursuit of this policy, the following are defined :

Sr. No.	Term	Meaning
---------	------	---------

(a)	Corrupt practice	The offering, giving, receiving, or soliciting, directly or indirectly, of anything of value to influence the action of a public official in the procurement process or in contract execution.
(b)	Fraudulent practice	a misrepresentation or omission of facts in order to influence a procurement process or the execution of a contract.
(c)	Collusive practice	means a scheme or arrangement between two or more bidders, with or without the knowledge of the purchaser, designed to establish bid prices at artificial, non-competitive levels.
(d)	Coercive practice	means harming or threatening to harm, directly or indirectly, persons or their property to influence their participation in the procurement process or affect the execution of a contract.
(e)	Anti-competitive practice	any collusion, bid rigging or anti-competitive arrangement, or any other practice coming under the purview of the Competition Act, 2002, between two or more bidders, with or without the knowledge of the purchaser, that may impair the transparency, fairness and the progress of the procurement process or to establish bid prices at artificial, non-competitive levels
(f)	Conflict of interest	participation by a bidding firm or any of its affiliates that are either involved in the consultancy contract to which this procurement is linked; or if they are part of more than one bid in the procurement; or if the bidding firm or their personnel have relationships or financial or business transactions with any official of purchaser who are directly or indirectly related to tender or execution process of contract; or improper use of information obtained by the (prospective) bidder from the purchaser with an intent to gain unfair advantage in the procurement process or for personal gain
(g)	Obstructive Practice	materially impede the purchaser's investigation into allegations of one or more of the above mentioned prohibited practices either by deliberately destroying, falsifying, altering; or by concealing of evidence material to the investigation; or by making false statements to investigators and/or by threatening, harassing or intimidating any party to prevent it from disclosing its knowledge of matters relevant to the investigation or from pursuing the investigation; or by impeding the purchaser's Entity's rights of audit or access to information.

ASSISTANCE TO BIDDERS

1. More information useful for submitting online bids on the CPP Portal may be obtained at: <https://eprocure.gov.in/eprocure/app>.
2. Any queries relating to the tender document and the terms and conditions contained therein should be addressed to the Tender Inviting Authority for a tender or the relevant contact person indicated in the tender.
3. Any queries relating to the process of online bid submission or queries relating to CPP Portal in general may be directed to the 24x7 CPP Portal Helpdesk. The contact number for the helpdesk is 1800 3070 2232, 91-7878007972 and 91-7878007973.

(Seal & Signature of bidder/tenderer)

SPECIAL INSTRUCTIONS TO BIDDERS FOR REGISTRATION WITH COMPETENT AUTHORITY

Bidders Registration

- 1) Any bidder from a country which shares a land border with India will be eligible to bid in any procurement whether of goods, services (including consultancy services and non-consultancy services) or works (including turnkey projects) only if the bidder is registered with the Competent Authority constituted by the Department for Promotion of Industry and Internal Trade (DPIIT).
- 2) **“Bidder”** for the purpose of this tender (including the term 'tenderer', 'consultant' 'vendor' or 'service provider' in certain contexts) means any person or firm or company, including any member of a consortium or joint venture (that is an association of several person, or firms or companies), every artificial juridical person not falling in any of the descriptions of bidders stated here in before, including any agency, branch or office controlled by such person, participating in a procurement process.
- 3) **“Bidder from a country which shares a land border with India”** for the purpose of this tender means:
 - a) An entity incorporated, established or registered in such a country; or
 - b) A subsidiary of an entity incorporated, established or registered in such a country; or
 - c) An entity substantially controlled through entities incorporated, established or registered in such a country; or
 - d) An entity whose beneficial owner is situated in such a country; or
 - e) An Indian (or other) agent of such an entity; or
 - f) A natural person who is a citizen of such a country; or
 - g) A consortium or joint venture where any member of the consortium or joint venture falls under any of the above
- 4) **“The Beneficial owner”** for the purpose of (3) above will be as under:

- i) In case of a company or Limited Liability Partnership, the beneficial owner is the natural person(s), who, whether acting alone or together, or through one or more juridical person(s), has a controlling ownership interest or who exercises control through other means.

Explanation:-

a) “Controlling ownership interest” means ownership of, or entitlement to, more than twenty-five per cent of shares or capital or profits of the company;

b) “Control” shall include the right to appoint the majority of the directors or to control the management or policy decisions, including by virtue of their shareholding or management rights or shareholders agreements or voting agreements;

- ii) In case of a partnership firm, the beneficial owner is the natural person(s) who, whether acting alone or together, or through one or more juridical person, has ownership of entitlement to more than fifteen percent of capital or profits of the partnership;

- iii) In case of an unincorporated association or body of individuals, the beneficial owner is the natural person(s), who, whether acting alone or together, or through one or more juridical person, has ownership of or entitlement to more than fifteen percent of the property or capital or profits of such association or body of individuals;

- iv) Where no natural person is identified under (i) or (ii) or (iii) above, the beneficial owner is the relevant natural person who holds the position of senior managing official;

- v) In case of a trust, the identification of beneficial owner(s) shall include identification of the author of the trust, the trustee, the beneficiaries with fifteen percent or more interest or more interest in the trust and any other natural person exercising ultimate effective control over the trust through a chain of control or ownership.

- 5) “Agent” for the purpose of this Order is a person employed to do any act for another, or to represent another in dealings with third persons.

6) **Sub-contracting in works contracts**

In works contracts, including turnkey contracts, contractors shall not be allowed to sub-contract works to any contractor from a country which shares a land border with India unless such contractor is registered with the Competent Authority.

***Please note that the bidders shall provide the mandatory Certificates in the following formats on their registered Company's letter heads:**

Certificate for Tenders involving procurement

“I/We have read the clause regarding restrictions of procurement from a bidder of a country which shares a land border with India and on sub-contracting to contractors from such countries; I/we certify that we are not from such a country or, if from such a country, have been registered with the Competent Authority and will not sub-contract any work to a contractor from such countries unless such contractor is registered with the Competent Authority. I/we hereby certify that we fulfill all requirements in this regard and is/are eligible to be considered. [Where applicable, evidence of valid registration by the competent Authority shall be attached.]”

(Seal & Signature of bidder/tenderer)

GENERAL TERMS AND CONDITIONS OF CONTRACT

1. **Submission of Tender:** Tenders should be uploaded on CPP portal in two parts separately, i.e. **"Technical Bid" (Part-A) and "Price Bid / BOQ" (Part-B)**. No other mode of submission will be accepted.
Any clarifications/amendments/corrigenda etc., to NIT before last date of submission of bid will only be available on our website: www.iuac.res.in. Therefore bidders are advised to keep visiting our website.
2. (i) **Technical Bid (Part-A)** : In this bid, the bidder shall upload the scan copies of the following essential documents to qualify the Technical bid (Pre-qualification Criteria) for the said item:
 - a) Registration certificate of the Company/Firm. The bidder must be a complete firm in the business of High vacuum Chamber fabrication and testing of similar type as in this NIT. The bidder should be in the similar business for at least last 10 years prior to the date of issue of the tender. The bidder should be a manufacturer who must have designed, manufactured, tested and supplied the equipment(s) similar to the type of specified in the technical specifications.
 - b) Tender Acceptance Letter (format attached with NIT) on bidder's Letter Head duly signed & stamped as a token of acceptance of the NIT conditions, terms, and conditions as per Annexure - B
 - c) Documents showing the company profile, organizational setup, and credentials
 - d) List of fabrication facilities, inspection facilities, vacuum leak testing & ultimate vacuum achieving facilities available with the vendor. A team of IUAC personnel may visit the bidder's sites for technical confirmation, if required.
 - e) Copies of work orders and Client's satisfactory certificates of similar type of works successfully completed, in the last five years, with reputed organizations, Govt. dept., Public sector & Autonomous bodies for minimum qualification. Either one work of value more than Rs. 28,00,000/- (Twenty Eight Lacs) or two works of value more than Rs.17,50,000/- (Seventeen lacs fifty thousand) each or three works of value more than Rs. 14,00,000/- (Fourteen lacs) each. Further, the bidder should have a minimum annual turnover of at least Rs. two crores for each of the last three financial years ending March 31, 2021. ITCC, Annual Report (Balance sheet and Profit & Loss account), along with copies of ITR, of last three financial years is required. In case balance sheet and statement of Profit & Loss for the immediate preceding financial year have not been prepared/audited, the account for one more preceding financial year can be submitted.
 - f) Bid Security Declaration as per Annexure - C
 - g) Code of Integrity Pact Certificate as per Annexure - D
 - h) Undertaking on a letterhead as per Annexure - E that firms have not been banned/blacklisted by any authority/Ministry/Department in the past.
 - i) Check list as per Annexure - F

(ii) Price Bid (Part-B):

In this bid, the bidder is required to quote his item rates in the BOQ formed in accordance with the scope of work, terms & conditions & technical specifications enclosed. The rates/price quoted by contractor should be all inclusive i.e. should include all material cost, labour, services, plant/machinery/tools & tackles, ladders & scaffolding required for work, freight, Insurance, and all applicable Govt. Duties, **excluding GST (payable separately, if applicable)**, levies & taxes, transport/cartage of materials/labour and all other expenses not specifically mentioned but reasonably implied. Nothing over and above these rates shall be payable to contractor.

Further, nothing extra in rates will be considered due to any site difficulties. It is mandatory for bidder to quote all items rate as asked for in the BOQ/ PRICE schedule. Failure in not filling some item rates will lead to be considered them as zero and accepted .No further compensation on that item can be considered later. The bidders should quote unconditional rates.

GST shall be paid as per GOI notification Nos. 45/2017 & 47/2017 dated 14/11/2017. The exemption certificate shall be provided at the time of issue of Work Order.

3. **Opening and Evaluation of E-Bids:**

- a) The E-bids shall be opened on-line. The price bid of only technically qualified bidders/tenderers will be opened.
- b) In case, the day of bid opening is declared a holiday by the government, the E-bids will be opened on the next working day at the same time. No separate intimation shall be sent to the bidders in this regard.
- c) Since E-bid is an online process, the E-bid opening or any other process may be delayed due to any technical/server issue. If any such issue arises, this will not be tantamount to process delay and IUAC will not be responsible for the same.
- d) On opening of bids online, accepting the bid would not mean that the firm is technically or financially qualified.

4. **Validity of Tender:** Tender shall be valid for our acceptance without any change in rates and NIT conditions for a period of 90 days from the date of opening of Price bid. No tenderer can withdraw/or modify his tender or revoke the same within the said period of 90 days. If a tenderer on his own withdraws or revokes the tender or revises or alters or modifies the tender for any item or condition within a period of aforesaid 90 days his performance security deposit shall stand forfeited and action will be taken as per Bid Security Declaration. The validity of accepted rates is extendable for a period of 180 days from the date of issue of Award Letter, with mutual consent of both the parties

5. **Escalation:** No escalation over and above items rates quoted by the bidder shall be paid during the execution of contract.

6. **Deviations:** No deviation from the stipulated terms and conditions will be allowed. Tender will be unconditional.
7. **Delivery Period:** The time shall be the essence of this work. The entire work is to be completed in two phases.
- a) **Phase-I :** The vendor is required to complete the fabrication of all components, within a period of 4 months (Four months) from the date of issue of the Purchase order. On receiving satisfactory inspection reports and pictures of fabricated components, IUAC personnel will inspect all the components at the vendor's site. The vendor will be required to assemble the Aluminium Spirals and Aluminium Spiral Posts in the Chambers in front of IUAC personnel. IUAC personnel will check the frequency etc. at the vendor's site.
- b) **Phase-II :** Final fabrication drawings of Copper Spiral & Copper Spiral Post will be given to the vendor after the completion of Phase-I. After receiving the drawings from IUAC, the vendor will be required to complete the remaining work within a further period of 1 month (one month). IUAC personnel may again visit the vendor's site for a final inspection. The vendor shall deliver all the components to IUAC, New Delhi within 15 calendar days (fifteen days) of final inspection.
- c) Any delay from IUAC's side e.g. delay in technical visit will be exempted from clause#22 (liquidity damages) but delay in completing the work for reasons attributable to the Supplier is liable for liquidated damages as per clause#22 of NIT. Under the force-majeure conditions or delay due to reasons beyond the control of the Supplier, IUAC may grant a suitable time extension for which the supplier has to request along with the justification/ reasons well in advance to the Director, IUAC for approval without any prejudice to price escalation. No time extension request shall be considered after the expiry of the completion period/contract. The decision of the Director, IUAC, will be final and binding on the bidder/Supplier.
8. **Terms of Payment:** 70% of the payment shall be made after the delivery of all the goods at IUAC. 20% of the total payment shall be made after successful technical inspection and acceptance of all the components at IUAC. The payment process will be initiated on the submission of the bills by the bidder and after due certification by the concerned IUAC personnel. Balance 10% shall be paid either after one year of the warranty period (as defined under clause # 21) or on submission of performance security in the form of bank guarantee of equal amount valid for 60 days beyond the date of all contractual obligations (12+2 months).
9. **Rules governing the Contractor's employees working in the IUAC Premises:**

Contractor will take due permission for entry of all his workmen in IUAC. No unauthorized person will be allowed to work inside IUAC campus. The contractor's employees working inside the IUAC campus will abide by the Centre's rules & regulations for works inside the

campus. Any damage to the IUAC property due to mishandling, carelessness on the contractor's or his workmen's part will be recoverable from the contractor's bills.

10. Force Majeure:

The right of the contractor/supplier to proceed with the work shall not be terminated because of any delay in the completion of the work due to unforeseeable causes beyond the control and without the fault or negligence of the contractor/supplier, including not limited to acts of God, Pandemic, or of the public enemy, restraints of a sovereign state, firms, wars, fires, epidemics, quarantine restrictions, floods, unusually severe weather. If a Force Majeure situation arises, the supplier/contractor shall promptly notify along with the justification/reasons well in advance to the Director IUAC for approval without any prejudice to price escalation. No time extension request shall be considered after the expiry of completion period/contract. The decision of the IUAC, Director will be final and binding on the supplier/contractor.

11. Jurisdiction:

Notwithstanding any other courts having jurisdiction to decide the questions forming subject matter of a suit any and all actions and proceedings arising out of or relative to this contract (including any arbitration in terms thereof) shall lie only in the court of competent Civil jurisdiction in this behalf at New Delhi., where this contract is to be signed on behalf of and only the said court shall have jurisdiction to try any such actions and/or proceedings to the exclusion of all other courts.

12. Tender liable to rejection:

Tenders which do not fulfill all or any of the conditions laid down in this notice, or contain conditions not covered and / or not contemplated by the Conditions of tender document and/or expressly prohibited therein or stipulate additional/alternative conditions shall be liable to be rejected and his earnest money will be forfeited. Tenders shall also be liable for rejection on any of the following grounds:-

- i. Tenders containing remarks uncalled for
- ii. Conditional tenders
- iii. Tenders not submitted on prescribed Proforma.
- iv. Tenders submitted late
- v. Tenders with NIL consideration
- vi. Not submitted required documents as per tender
- vii. The prospective bidders having same board member/members

13. IUAC not to assign any reason for rejection of tender:

Director, IUAC hold absolute discretion to accept or reject the lowest or any other tender without assigning any reason. No claim on this account shall be entertained.

14. **Amendment in tender documents:**

IUAC reserve the right to revise or amend the Bid Documents upto the date prior to the date notified for opening of the tenders and also the right to postpone the date of submission and opening of tenders without assigning any reason, whatsoever.

15. IUAC will not pay any expense, whatsoever incurred by tenderer for the preparation and submission of tenders.

16. IUAC does not bind itself to accept the lowest or any tender and reserves the right to reject any of all tenders without assigning any reason.

17. The notice inviting tender, will form part of the contract agreement to be executed by the successful tenderer with the IUAC.

18. **Termination for Insolvency:** IUAC may at any time terminate the Contract by giving written notice to the Supplier, if the supplier becomes bankrupt or otherwise insolvent. In this event, termination will be without compensation to the Supplier, provided that such termination will not prejudice or affect any right of action or remedy, which has accrued or will accrue thereafter to the Purchaser.

19. **Negotiations** : Normally, there shall not be any negotiations. Negotiations, if at all, shall be an exception and only in the case of items with limited source of supply. Negotiations shall be held with the lowest evaluated responsive bidder.

20. **Pre-dispatch Inspection:** All the items will be subjected to pre-dispatch inspection and shall be rejected if any defects are found before dispatch.

21. **Warranty Period:** The items supplied must be covered under a minimum one-year Warranty/Guarantee, commencing from the date of the satisfactory acceptance of all the equipment at IUAC, against the defect of any manufacturing, workmanship, and poor quality of the component. The vendor will be required to replace/repair the defective components free of cost.

22. **Liquidity damages:** In case of supply is delayed beyond the specified completion period for reason attributable to the bidder, deduction on account of liquidated damages @ 1% of the order value per week will be deducted subject to a maximum of 10% of the total work order value.

23. **Scope of Work:** Supply of items as per technical specifications given in Annexure-A.

24. **Material Test Certificate:** A test certificate for the material used has to be submitted before the start of fabrication and during on-site delivery of the components. In addition, the test may be conducted by IUAC on samples from completed components, if required.

25. IUAC also reserves the right to change the quantities of the units while issuing the letter of award of work.

26. IUAC reserves the right to reject any or all the tenders in full or in part without assigning any reasons whatsoever, and the decision of the IUAC in this regard will be binding on all the bidders. Tenders not complying with any of the provisions stated in this tender document are liable to be rejected. Director, IUAC reserves the right to accept or reject any tender without assigning any reason and does not bind himself to accept the lowest tender.

27. **Correspondence**: All the correspondence in respect of tender/award of work shall be made to A.O. (S&P), IUAC, Aruna Asaf Ali Marg, New Delhi-110067.

(Seal & Signature of bidder/tenderer)

SPECIAL TERMS AND CONDITIONS OF CONTRACT /WORK

1. CARRYING OUT OF WORK

All the work shall be carried out in accordance strictly as per the specifications given in the tender to the total satisfaction of the Institute

2. CONTRACTOR'S RESPONSIBILITY FOR THE MANNER OF EXECUTION OF WORKS

The contractor shall be solely responsible for the manner and the method of executing the work. The work shall be subject to the approval of IUAC from time to time for purposes of determination of the question whether the work is executed by the contractor in accordance with the contract.

3. SPECIFICATIONS:

During execution of work, the contractor should follow all standard norms of safety measures/precautions as per relevant codes to avoid accidents/damages to man, machines and buildings, at his own cost. If specifications for an item of work are not covered as per approved Specifications of tender, the same shall be decided by the Institute and shall be binding on the contractor.

4. AGENCY'S RISKS

All risks of loss of a or damage to physical property and of personal injury and death which arise during and in consequence of the performance of the contract other than the excepted risks are the responsibility of the contractor.

5. ACTION AND COMPENSATION PAYABLE IN CASE OF BAD WORK:

If it shall appear to IUAC, or our representatives, that any work has been executed with unsound, imperfect or unskillful workmanship **then the contractor shall be liable to pay compensation.** If during the execution of works, any damage is caused to IUAC property by contractor's workers, contractor will duly make good the loss. IUAC has the right to make suitable deduction from contractor's bills along with penalty, if contractor fails to make good the loss.

No material belonging to the contractor whether consumable or non-consumable should be brought inside the IUAC campus without proper entry at the Main Gate nor any material should be taken out without proper gate pass issued by the authorized representatives of the Centre. Material delivery challans duly entered at the main gate shall to be submitted. It shall always prevail, unless otherwise specifically stated, that the entire provisions of Tender document been opened upon and accepted for compliance by the contractor without any reservation.

- 6.** If during the execution of works, any damage is caused to IUAC property by contractor's workers, contractor will duly make good the loss. IUAC has the right to make suitable deduction from contractor's bills along with penalty, if contractor fails to make good the loss.

7. During execution of work, the contractor should follow all standard norms of safety measures/precautions as per relevant codes to avoid accidents/damages to man, machines and buildings, at his own cost. Contractor will have his own arrangement to escort the labour to the nearest hospital for treatment in case any injury happens to any worker during execution of work.

Seal & Signature of Contractor

ANNEXURE-A

Scope of Work : FABRICATION, ASSEMBLING, TESTING & SUPPLY OF TWO Nos. OF HEBT SPIRAL BUNCHERS WORKING UNDER HIGH VACUUM AS PER DRAWINGS & SPECIFICATIONS AND TERMS & CONDITIONS:

- 1 **EXCEPT FOR FOUR NOS. OF END PLATES (DRAWING NO.–IUAC/485BUN/03), IUAC WILL NOT SUPPLY ANY OTHER MATERIAL.** The raw material for these four nos. of endplates is OFHC copper of size = 1000mm x 1000mm x 30mm, which will be supplied by IUAC. Any rejection will be borne by the vendor.
- 2 The vendor will be required to submit the material test certificates of all the materials used, from the manufacturer or recognized Laboratory before the start of fabrication.
For work phases, please see Point # 7 (Delivery Period) under General Terms & Conditions of Contract.

The following Drawings are attached with the NIT for initial reference:

Drawing No.	Description
a. IUAC/ HEBT/BUN /01	Assembly Drawing
b. IUAC/ HEBT/BUN /02	Vacuum Chamber
c. IUAC/ HEBT/BUN /03	End Plate
d. IUAC/ HEBT/BUN /04	Spiral (Cu)
e. IUAC/ HEBT/BUN /05	Spiral (Al)
f. IUAC/ HEBT/BUN /06	Spiral Post (Cu)
g. IUAC/ HEBT/BUN /07	Spiral Post (Al)
h. IUAC/ HEBT/BUN /08	Central Drift Tube
i. IUAC/ HEBT/BUN /09	Side Drift Tube
j. IUAC/HEBT/BUN /10	Cooling Plate

- 3 The quantity of each item and other specifications are given in the drawings.
- 4 A complete set of detailed drawings, except standard components, will be supplied along with the Purchase order.
- 5 The chamber material is forged low carbon steel AISI -1020 or SA-105 of equivalent grade material.
- 6 The vendor will be required to supply the entire copper blank off flanges, good quality S.S.304 nuts, socket head cap screws, I-bolts & washers, and one complete set of Viton O-rings of the required quantity and sizes.

- 7 Aluminium Spiral & Aluminium Spiral Post are required for frequency testing only. Copper Spiral & Copper Spiral Post will be fabricated after testing of frequency etc. with the Aluminium Spiral & Aluminium Spiral Post inside the Chamber. Final drawings of Copper Spiral & Copper Spiral Post will be given to the vendor after frequency testing with the aluminium ones at the vendor's site.
- 8 The inside surfaces of the chamber should have a mirror finish i.e. surface roughness of N4-N5 grade or of Ra-0.2-0.4µm.
- 9 No dent or scratch will be tolerated on the entire inside surface of the chamber, O ring grooves, and the surfaces which seal the rubber O'rings.
- 10 Overall length, internal diameter, and circularity of the chamber have to be maintained within an accuracy of ± 1.0 mm.
- 11 Vacuum Testing: - The vacuum chambers will be subjected to vacuum leak testing with helium in front of IUAC personnel once at the vendor's site and once at the IUAC site after delivery. The leak rate should be better than 1×10^{-9} mbar lt/sec. The ultimate vacuum of the chambers should be better than 1×10^{-8} mbar.
- 12 Spiral is made of two components i.e. Spiral Base and Spiral Blankoff. The Spiral base has a water cooling channel in it and the Spiral Blank off to be Vacuum Brazed with the Spiral Base to seal the cooling channels. The vendor should keep sufficient machining allowance to nullify the distortions with machining after brazing. *(Please refer to the drawings also for more technical specifications.)*
- 13 High-pressure testing (hydrostatic) @ 5 bar, as well as helium leak vacuum testing, is required for the Spiral water circuits after brazing.
- 14 Spiral should be vacuum leak checked once after brazing and once after the final machining.
- 15 The vendor is required to assemble all the components inside the tank and test for high pressure and vacuum simultaneously at factory site, as well as for dimensional accuracy.
- 16 All the cooling plates are to nickel-chrome electroplated with minimum plating thickness of 10 microns, as mentions in the drawing IUAC/HEBT/BUN /10.
- 17 Packing and forwarding the final components after the completion to IUAC. The Spiral (Cu) should be packed separately. All the items should be packed without any damage or scratch on the surface. Packing shall be strong enough and shock resistant to withstand any damage to the chamber and other components either by air or road.
- 18 The vendor is free to ask and clear any doubt from authorized IUAC personnel.
- 19 Minor changes in design by IUAC should be allowed without any extra cost.

- 20 The vendor should read all the drawings carefully for detailed technical specifications etc. and ask clarifications from IUAC personnel if required before bidding.

Quality Control (Inspection and Testing)

The vendor should have an independent quality control division and its report shall be forwarded to concerned IUAC personnel. A detailed quality assurance program (QAP) shall be chalked out and shall be communicated to IUAC in writing.

The work shall be inspected at various stages of manufacturing to fulfill the requirement and specification as per the drawings. These reports shall be easily accessible to IUAC personnel. Authorized IUAC personnel will also be allowed for witnessing the quality control program for critical processes and operations. The total quality control documents shall be submitted to IUAC along with other necessary documents.

7. Quality control for materials.

All the materials procured for the chamber/tank and other components shall conform to the material specifications. The laboratory certificates and test reports shall be provided to IUAC as and when required.

8. Quality control for dimensional accuracy, and surface finish

Dimensional accuracy of the chamber/ tank and other components shall be checked and a report shall be generated and submitted to IUAC. The assembled chamber/tank, end blank offs, Stems, Spiral, etc shall be tested for assembly dimensional accuracy. Please contact IUAC personnel for further details on tank assembly inspection.

The surface finish of the components shall be checked with calibrated instruments as specified in the drawings.

9. Quality test for leak-proof joints and brazing

All the assembled parts, as well as the individual parts, shall be done leak testing using a helium mass spectrometer. The brazed joints shall be pressure tested as well as helium mass spectrometer checked. The helium leak testing set up shall be calibrated with a standard leak to have a detection capability better than 1×10^{-10} Torr-Lit/sec on site.

MATERIALS

All the materials used for the chamber/ tank and other components shall be fresh and procured from reputed suppliers/manufacturers. The materials to be used for the fabrication, as well as machined components, shall be protected against any damages/scratches/ dents or weathering.

1. Chamber/Tank material

Forged low carbon steel conforming AISI 1020 / SA 105 or equivalent steel is chosen for the tanks. To ensure a defect-free tank, the supplier shall do a radiography/ultrasound test to detect porosity. This material would give a thermal conductivity of 50w/m-k at room temperature for additional information please contact concerned IUAC personnel.

2. Copper Stem & Copper Spiral and blank off material : Electrolytic Tough Pitch (ETP) copper C11000 grade

3. Fasteners & Elastomers :

Fasteners for use in this work shall be made of stainless steel material grade 304.

Fluorocarbon (Viton) elastomers with exceptional resistance to radiation, temperature, and low gas permeability shall be used with black color.

Note : For additional information please contact concerned IUAC personnel.

Cleaning, Handling, Storage, and Shipment

The Buncher is an accelerating structure, therefore the RF surface will see the high electric field, so surface cleanliness and smoothness are very important. The avoidable oils and acids from the machine as well as human skin shall be avoided. Disposable gloves and lint-free papers shall be used, and the handlers shall be sensitized to these requirements. Additives containing sulfur, silicon, and halogens shall be avoided. Cutting fluids shall be removed after the machining operation immediately. Avoid cutting oil accumulated for a long duration of machining operation.

Transport and temporary storage during the machining and assembly of the Buncher components should be done in such a way that no damage or contamination on the surfaces. Buncher components shall be packed with cling foil and PUF packing. Buncher components should not be left lying out in the open where they may be exposed to dust and inadvertent handling of personnel.

Before the shipment, the vendor shall make sure that all the items in the scope of the supply are fully included in the packing boxes. Packing cases must be robust enough to take care of the impact during handling and transportation. A suitable stiffener and cushion should be provided for movement and vibration during transportation.

After final tank assembly before shipment to IUAC, inert gas with positive pressure and shall be shipped with silica desiccant packets to avoid moisture exposure on the RF surface.

ANNEXURE - B

TENDER ACCEPTANCE LETTER

(To be given on Bidders/ Company Letter Head)

Date: _____

To

The Director

Inter-University Accelerator Centre

Aruna Asaf Ali Marg

New Delhi-110 067.

Sub: Acceptance of Terms & Conditions of Tender.

Tender Reference No: _____

Name of Tender / Work: _____

Dear Sir,

1. We have downloaded / obtained the tender document(s) for the above mentioned 'Tender/Work' from the web site(s) namely: as per your advertisement, given in the above mentioned website(s).
2. We hereby certify that we have read the entire terms and conditions of the tender documents from Page No. _____ to _____ (including all documents like annexure(s), schedule(s), etc .), which form part of the contract agreement and we shall abide hereby by the terms / conditions / clauses Contained therein.
3. The corrigendum(s) issued from time to time by your department/ organizations too have also been taken into consideration, while submitting this acceptance letter.
4. We hereby unconditionally accept the tender conditions of above mentioned tender document(s) / corrigendum(s) in its totality / entirety.
5. We do hereby declare that our Firm has not been blacklisted/ debarred by any Govt. Department/ Public sector undertaking.
6. We certify that all information furnished by the our Firm is true & correct and in the event that the information is found to be incorrect/untrue or found violated, then your department/ organization shall without giving any notice or reason therefore or summarily reject the bid or terminate the contract, without prejudice to any other rights or remedy including the forfeiture of the full said earnest money deposit absolutely.

Yours Faithfully,

(Signature of the Bidder, with Official Seal)

Part-B
PRICE BID

(Price should be quoted in the standard BOQ format of this tender, Incomplete price bid will be rejected)

Tender Inviting Authority: INTER UNIVERSITY ACCELERATOR CENTRE

Name of Work/Supply: FABRICATION, ASSEMBLING, TESTING & SUPPLY OF TWO (2) NOS. OF SPIRAL BUNCHER WORKING UNDER HIGH VACUUM AS PER DRAWINGS & SPECIFICATIONS.

S.No.	Description	Qty (Nos)
1.	FABRICATION, ASSEMBLING, TESTING & SUPPLY OF TWO (2) NOS. OF SPIRAL BUNCHER WORKING UNDER HIGH VACUUM AS PER DRAWINGS & SPECIFICATIONS	02

ANNEXURE - C
BID SECURING DECLARATION FORM

Tender/Bid No.:

Date:

To
The Director
IUAC, New Delhi

Dear Sir,

I/We. The undersigned, declare that:

I/We understand that, according to your conditions, bids must be supported by a Bid Securing Declaration.

I/We accept that I/We may be disqualified from bidding for any contract with you for a period of one year from the date of notification, if I am /We are in a breach of any obligation under the bid conditions, because I/We,

- a** have withdrawn/modified/amended, impairs or derogates from the tender, my/our Bid during the period of bid validity specified in the form of Bid; or
- b** having been notified of the acceptance of our Bid by the purchaser during the period of bid validity (i) fail or reuse to execute the contract, if required, or (ii) fail or refuse to furnish the Performance Security, in accordance with the Instructions to Bidders.

I/We understand this Bid Securing Declaration shall cease to be valid if I am/we are not the successful Bidder, upon the earlier of (i) the receipt of your notification of the name of the successful Bidder; or (ii) 28 days after the expiration of the validity of my/our Bid.

Signed:

Name:

Dated on _____ day of _____

Corporate Seal (where appropriate)

(Note: In case of a Joint Venture, the Bid Securing Declaration must be in the name of all partners to the Joint Venture that submits the bid)

ANNEXURE - D

Format for declaration by the Bidder for Code of Integrity & conflict of interest

(On the Letter Head of the Bidder)

No: _____

Date _____

To,
The Director
IUAC, New Delhi

Sir,

With reference to your Tender No. _____ dated _____ I/We hereby declare that we shall abide by the Code of Integrity for Public Procurement as in your Tender document and have no conflict of interest.

It is certified that we are not associated, or have been associated in the past, directly or indirectly, with a firm or any of its affiliates which have been engaged by the Purchaser to provide consulting services for the preparation of the design, specifications, and other documents to be used for the procurement of the goods to be purchased under this Invitation of Bids / Tender.

The details of any previous transgressions of the code of integrity with any entity in any country during the last three years or of being debarred by any other Procuring Entity are as under:

- a
- b
- c

We undertake that we shall be liable for any punitive action in case of transgression/ contravention of this code.

Thanking you,

Yours sincerely,

Signature
(Name of the authorized signatory)

Company Seal

ANNEXURE - E
(Undertaking on Bidder's Letterhead)

I / We (bidder) hereby give an undertaking that:

1. I / We have not been blacklisted / on holiday list / debarred during last three years by any Govt. Department/Govt. Autonomous Body/Institution, etc.;
2. I/We do not have any dispute with any of the Govt. Departments/ Govt. Autonomous Bodies/Institutions, etc.;
3. I/We have never been certified as 'Unsatisfactory Performer' for the said services provided to the Govt. Departments/ Govt. Autonomous Bodies/ Institutions;
4. I/We have not submitted any fake/forged certificates/ documents and later, if any such 'Certificates/Documents' found to be fake/ forged or contains willful wrong/incorrect information, suitable legal actions may be initiated against me/us/agency and the agencies / bidders shall be debarred from tendering with the Institute.
5. I/We shall not withdraw my/our bid after opening of Technical Bid and if done so, the IUAC and the agencies / bidders shall be debarred from tendering with the Institute.

Authorized

Seal and Signatures of the

Person of the Agency
Name and designation of the
Authorized Person of the Agency

Place:

Date:

ANNEXURE - F

CHECK-LIST FOR PRE-QUALIFICATION BID FOR:

SUPPLY FABRICATION, ASSEMBLING, TESTING & SUPPLY OF TWO (2) NOS. OF SPIRAL BUNCHERS WORKING UNDER HIGH VACUUM AS PER DRAWINGS & SPECIFICATIONS

S. No.	Documents asked for	Page number at which the document is placed
1.	Tender Acceptance Letter as per Annexure B	
2.	Bid Securing Declaration as per Annexure-C	
3.	Code of Integrity and Conflict of Interest as per Annexure-D	
4.	Undertaking as per Annexure - E that firms have not been banned/blacklisted	
	Documents showing the company profile, organizational setup, and credentials	
5.	Signed copy of Tender document	
6.	Self-attested copy of the GSTIN & PAN card issued by the Income Tax Department.	
7.	Copies of work orders and Client's satisfactory certificates	
8.	Annual turnover, along with copies of ITR, of last three financial years ending March 31 st 2020 duly certified by the Statutory Auditors. In case balance sheet and statement of Profit & Loss for the immediate preceding financial year have not been prepared/audited, the account for one more preceding financial year can be submitted.	
9.	Registration Certificate	
10.	List of fabrication and inspection facilities	
11.	Any other document asked for in this NIT	

Signature of the Bidder

(Name and Address of the Bidder)

Company Seal

Attachments :

(i) Set of drawings (IUAC/HEBT/BUN/01 to 10)

* * * End of NIT * * *

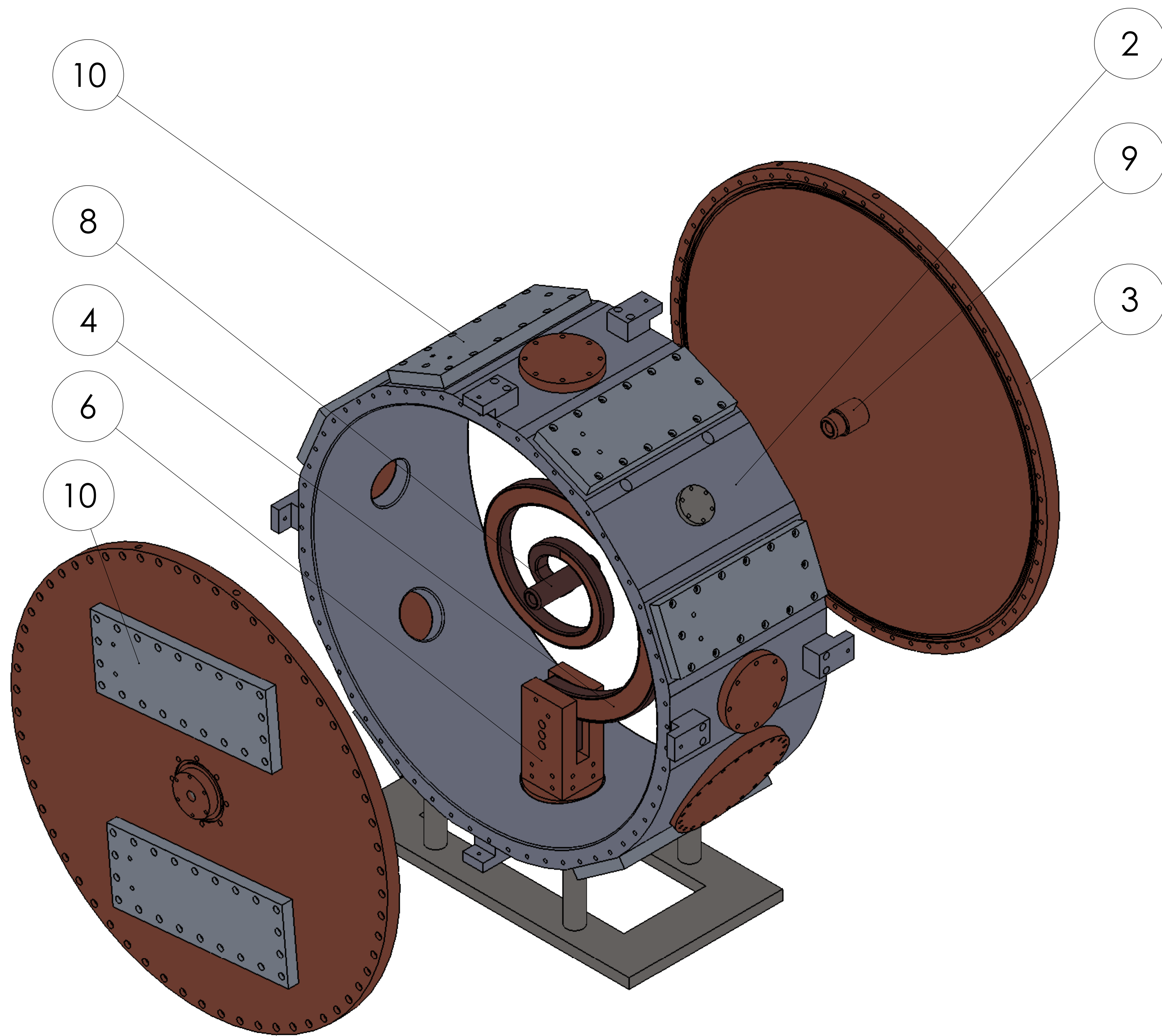

NOTE :

1. EXCEPT FOR FOUR NOS. OF END PLATES (DRAWING NO.-IUAC/485BUN/03), IUAC WILL NOT SUPPLY ANY OTHER MATERIAL. The raw material for these four nos. of endplates is OFHC copper of size = 1000mm x 1000mm x 30mm, which will be supplied by IUAC. Any rejection will be borne by the vendor.
2. Material test certificates of all the materials used, from the manufacturer or recognized Laboratory to be submitted before the start of fabrication.
3. The quantity of each item and other specifications are given in the individual drawings.
4. The vendor will be required to supply the entire copper blank off flanges, good quality S.S.304 nuts, socket head cap screws, I-bolts & washers, and one complete set of Viton O-rings of the required quantity and sizes.
5. Aluminium Spiral & Aluminium Spiral Post are required for frequency testing only. Copper Spiral & Copper Spiral Post will be fabricated after testing of frequency etc. with the Aluminium Spiral & Aluminium Spiral Post inside the Chamber. Final drawings of Copper Spiral & Copper Spiral Post will be given to the vendor after frequency testing with the aluminium ones at the vendor's site. The inside surfaces of the chamber should have a mirror finish i.e. surface roughness of N4-N5 grade or of Ra-0.2-0.4µm.
6. No dent or scratch will be tolerated on the entire inside surface of the chamber, O ring grooves, and the surfaces which seal the rubber O'rings.
7. Overall length, internal diameter, and circularity of the chamber have to be maintained within an accuracy of + 1.0 mm.
8. Vacuum Testing: - The vacuum chambers will be subjected to vacuum leak testing with helium in front of IUAC personnel once at the vendor's site and once at the IUAC site after delivery. The leak rate should be better than 1x10⁻⁹ mbar l/sec. The ultimate vacuum of the chambers should be better than 1x10⁻⁸ mbar.
9. Spiral is made of two components i.e. Spiral Base and Spiral Blankoff. The Spiral base has a water cooling channel in it and the Spiral Blank off to be Vacuum Brazed with the Spiral Base to seal the cooling channels. The vendor should keep sufficient machining allowance to nullify the distortions with machining after brazing. (Please refer to the drawings also for more technical specifications.)
10. High-pressure testing (hydrostatic) @ 5 bar, as well as helium leak vacuum testing, is required for the Spiral (Cu) water circuits after brazing.
11. Spiral should be vacuum leak checked once after brazing and once after the final machining.
12. Assemble all the components inside the tank and test for high pressure and vacuum simultaneously at factory site, as well as for dimensional accuracy also.

Part No. (IUAC/HEBT/BUN/..)	Description	Quantity per Spiral Buncher	Material
10	Cooling Plate	10	Aluminium
09	Side Drift Tube	02	ETP Copper
08	Central Drift Tube	01	ETP Copper
07	Spiral Post (Al)	01	Aluminium
06	Spiral Post (Cu)	01	ETP Copper
05	Aluminium Spiral	01	Aluminium
04	Copper Spiral	01	ETP Copper
03	End Plate	02	IUAC supplied OFHC copper
02	Vaccum Chamber	01	Low carbon steel

TOLERANCES: ONE PLACE DECIMAL ± 0.1mm TWO PLACE DECIMAL ± 0.02mm FRACTIONAL ± ANGULAR ± 0/02 deg.		DEBUR AND BREAK SHARP EDGES ALL DIMENSIONS ARE IN MM		Inter University Accelerator Centre Formerly : Nuclear Science Centre New Delhi - 110067
DRAWN: SKS CHCD: RA APPVD: CPS MFG: QA:	NAME: SKS SIGNATURE: RA DATE: 03.08.21 DATE: 03.08.21	TITLE: Buncher Assembly	DWG NO.: IUAC/HEBT/BUN/01 SHEET 1 OF 1	A1 Rev - 1

DRAWING FOR ESTIMATION PURPOSE ONLY

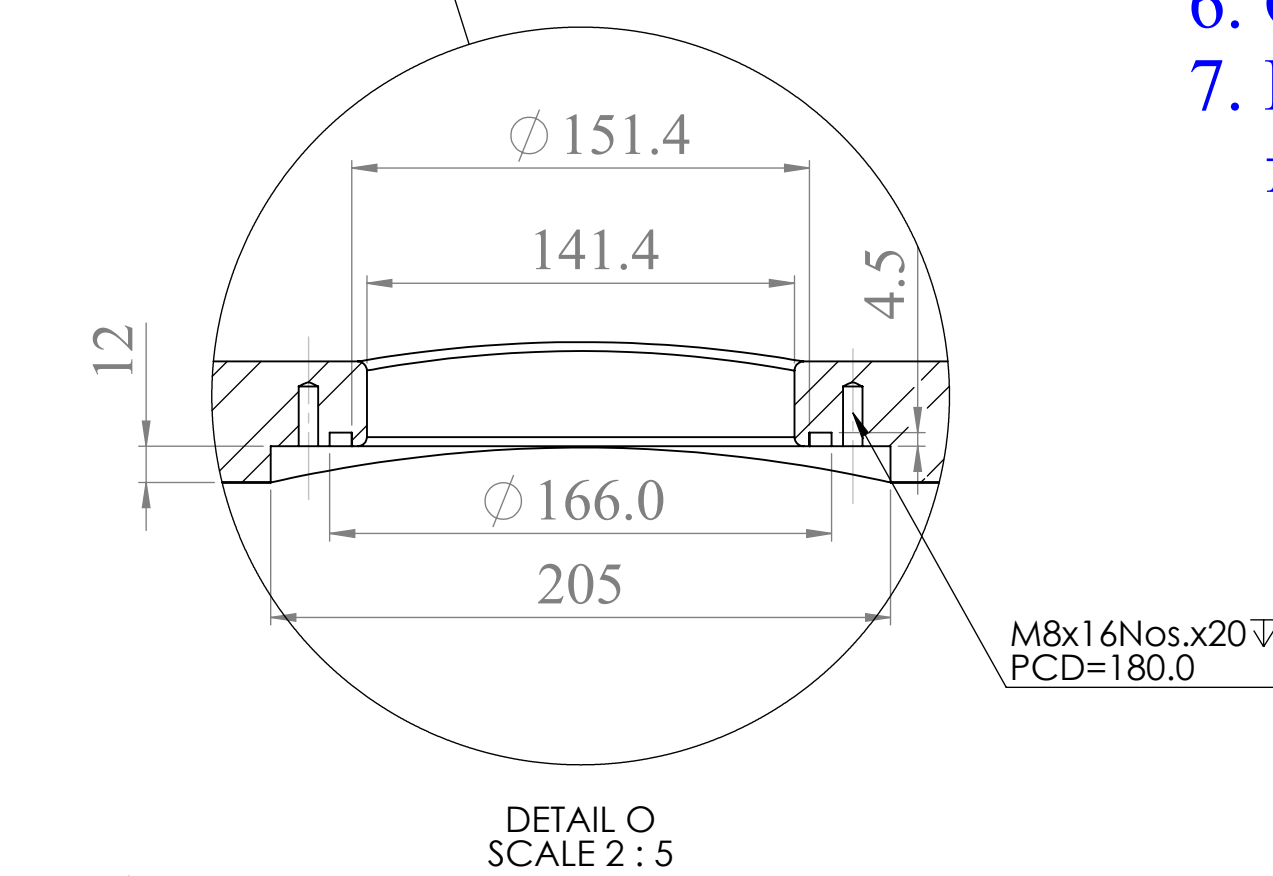
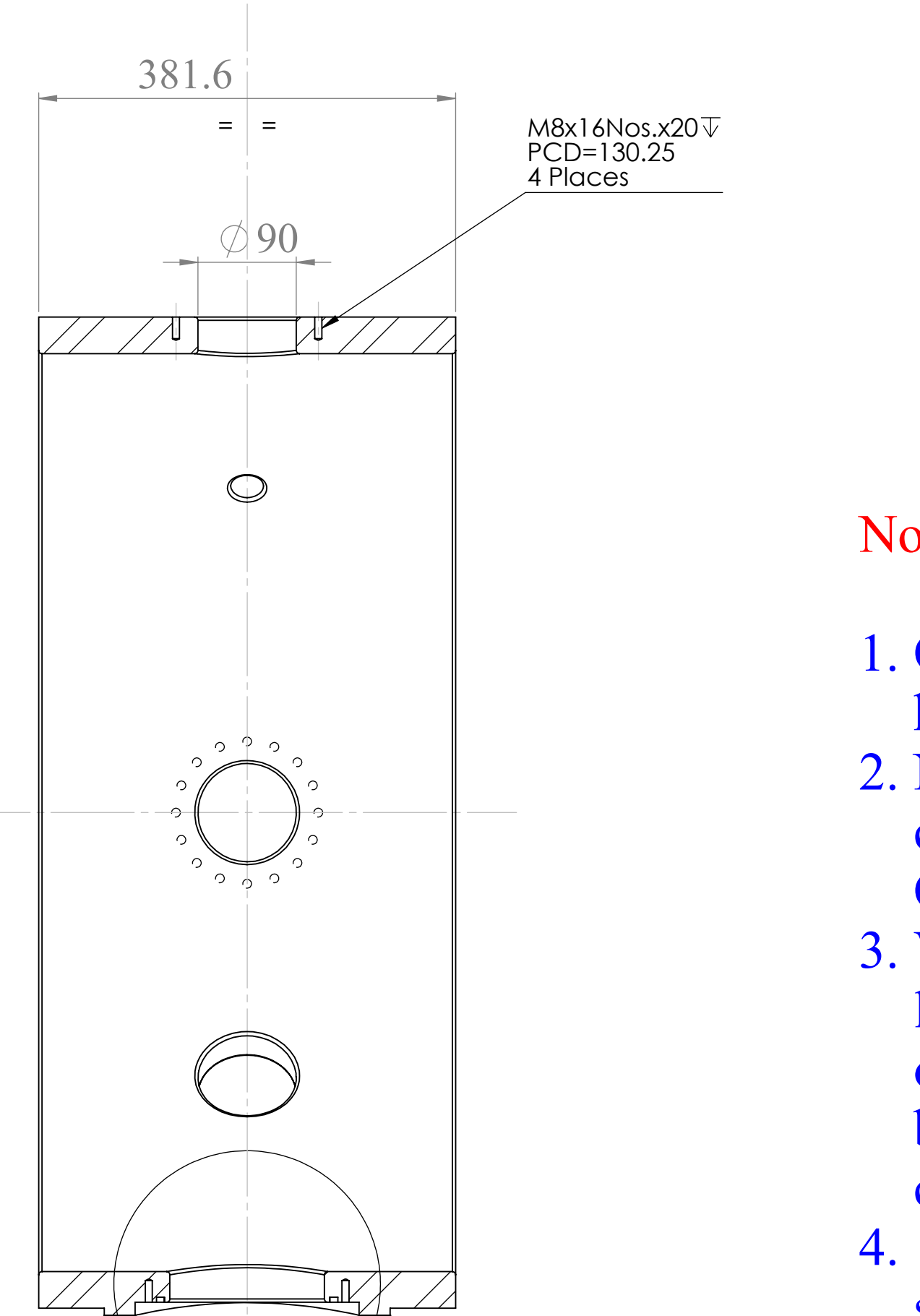
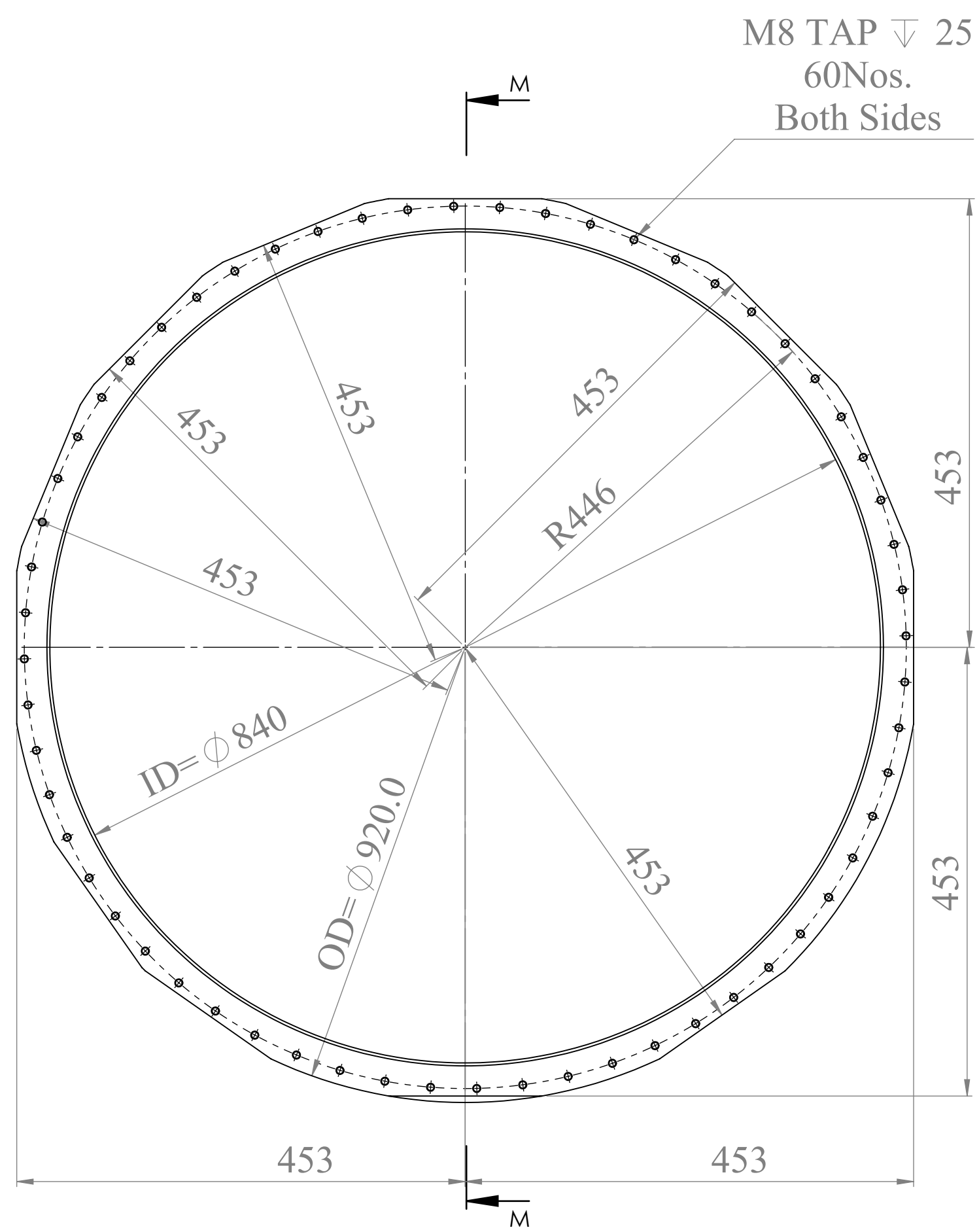
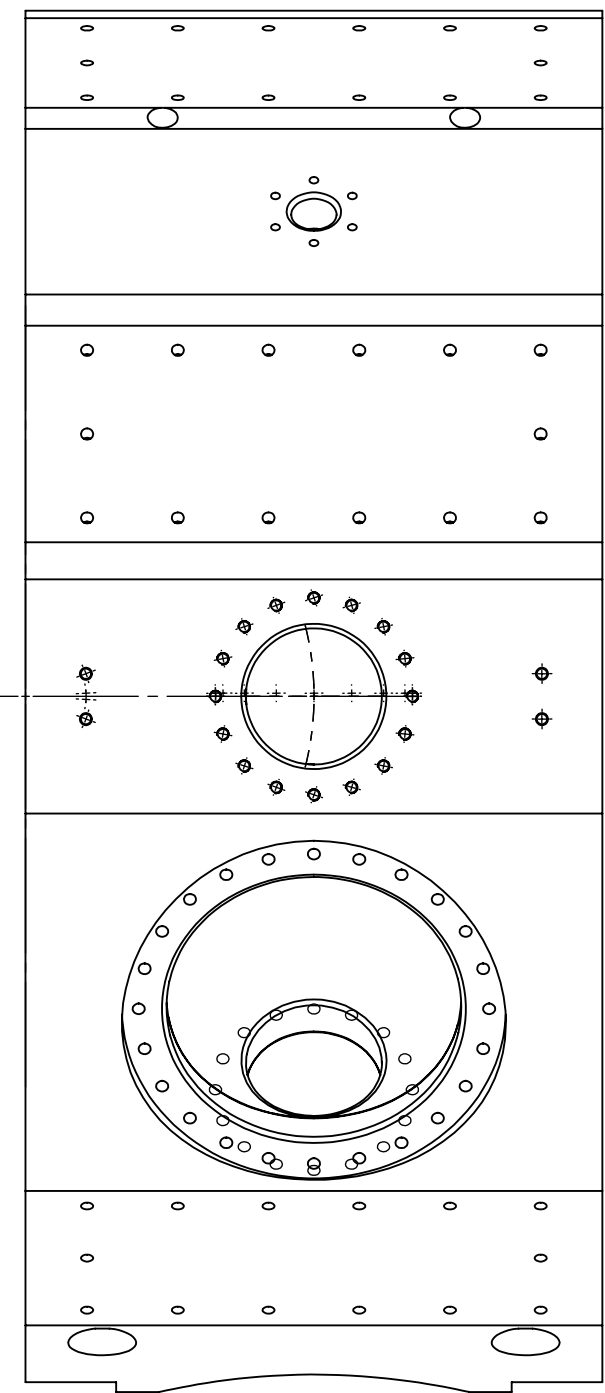
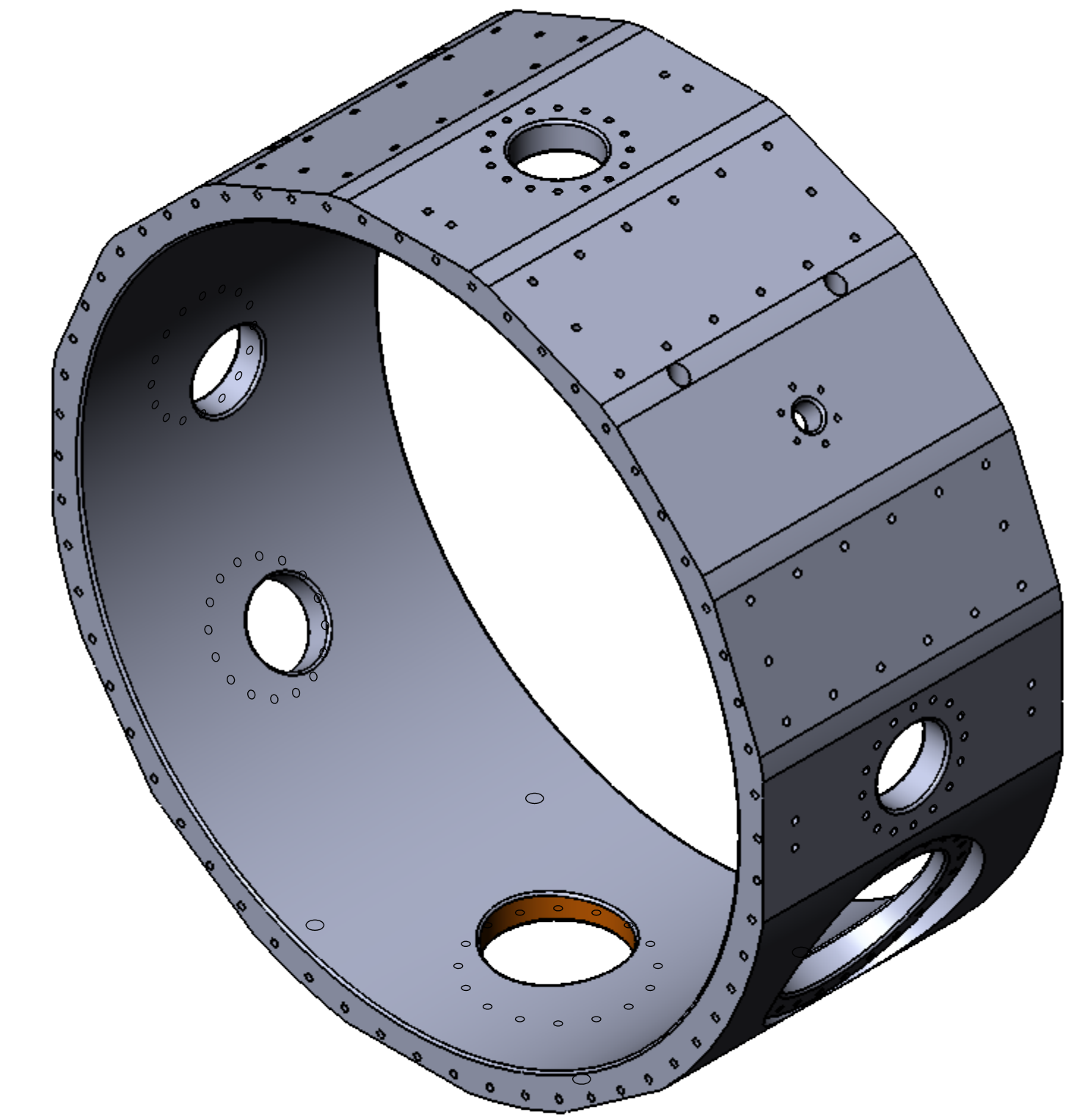
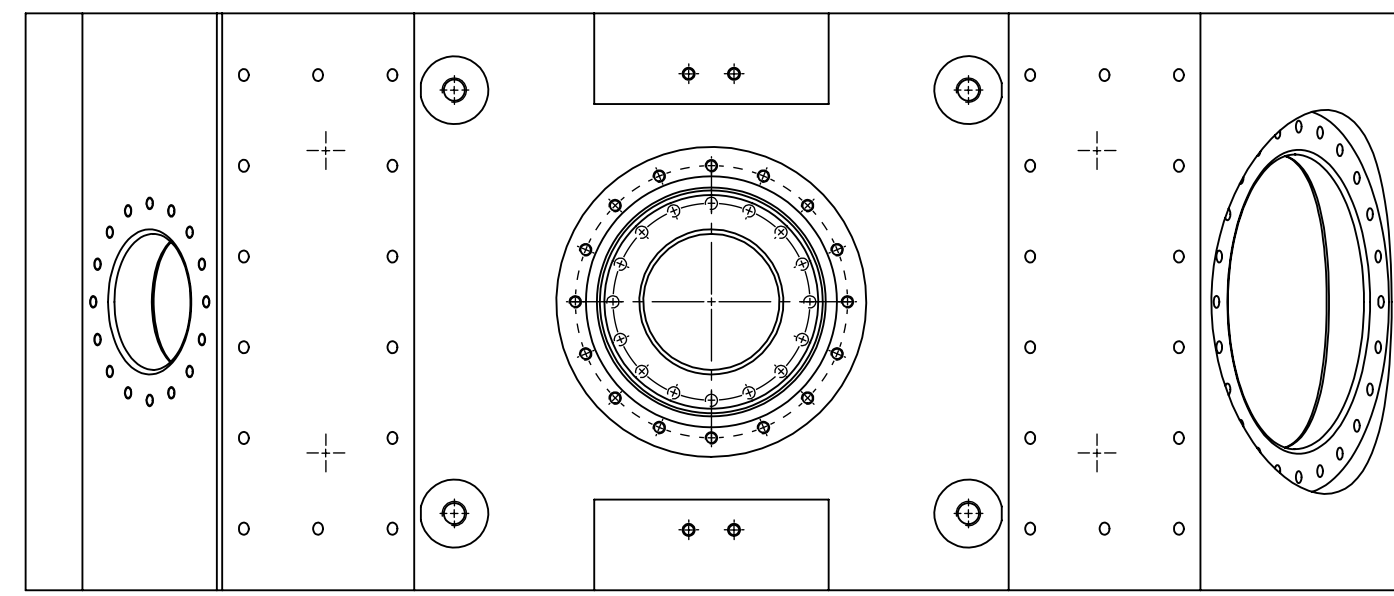

- Note :**
- Overall length, internal diameter and circularity of the chamber has to be maintained within an accuracy of 1.0 mm
 - No dent or scratch will be tolerated on inside surface of the chamber, O ring grooves and the surfaces which seal the rubber O rings.
 - Vacuum Testing:- The vacuum chambers will be subjected to leak testing in front of IUAC personnel once at vendor's site and once at IUAC site after delivery and helium leak rate should be better than 1×10^{-9} mbar.lt/sec. Ultimate vacuum of the chambers should be better than 1×10^{-8} torr.
 - The inside surfaces of chamber should have mirror finish i.e surface roughness of N4-N5 grade or of Ra-0.2-0.4um because IUAC will perform copper plating on the chambers.
 - Please contact IUAC authorised personnel for any doubt or clarification.
 - Give Fillet radius of R2 on every sharp edges.
 - Please refer front view and sectional view on Sheet 2 & 3 of 3 for more details.

DRAWINGS FOR ESTIMATION PUPOSE ONLY

TOLERANCES			DEBUR AND BREAK SHARP EDGES		Inter University Accelerator Centre Formerly : Nuclear Science Centre New Delhi - 110067	
ONE PLACE DECIMAL	TWO PLACE DECIMAL	FRACTIONAL	ALL DIMENSIONS ARE IN MM		TITLE:	
$\pm 0.1mm$	$\pm 0.02mm$	$\pm 0.02 deg.$			VACUUM CHAMBER	
					<i>Main View</i>	
DRAWN	NAME	SIGNATURE	DATE		DWG NO.	A1
CHKD			23.03.21		IUAC/HEBT/BUN /02	
APPVD						
MFG						
QA						
			MATERIAL: Forged low carbon steel AISI 1020 / SA-105 or equivalent		SCALE:1:5	
			Qty : 2 Nos.		SHEET 1 OF 3 Rev - 1	
			WEIGHT:			

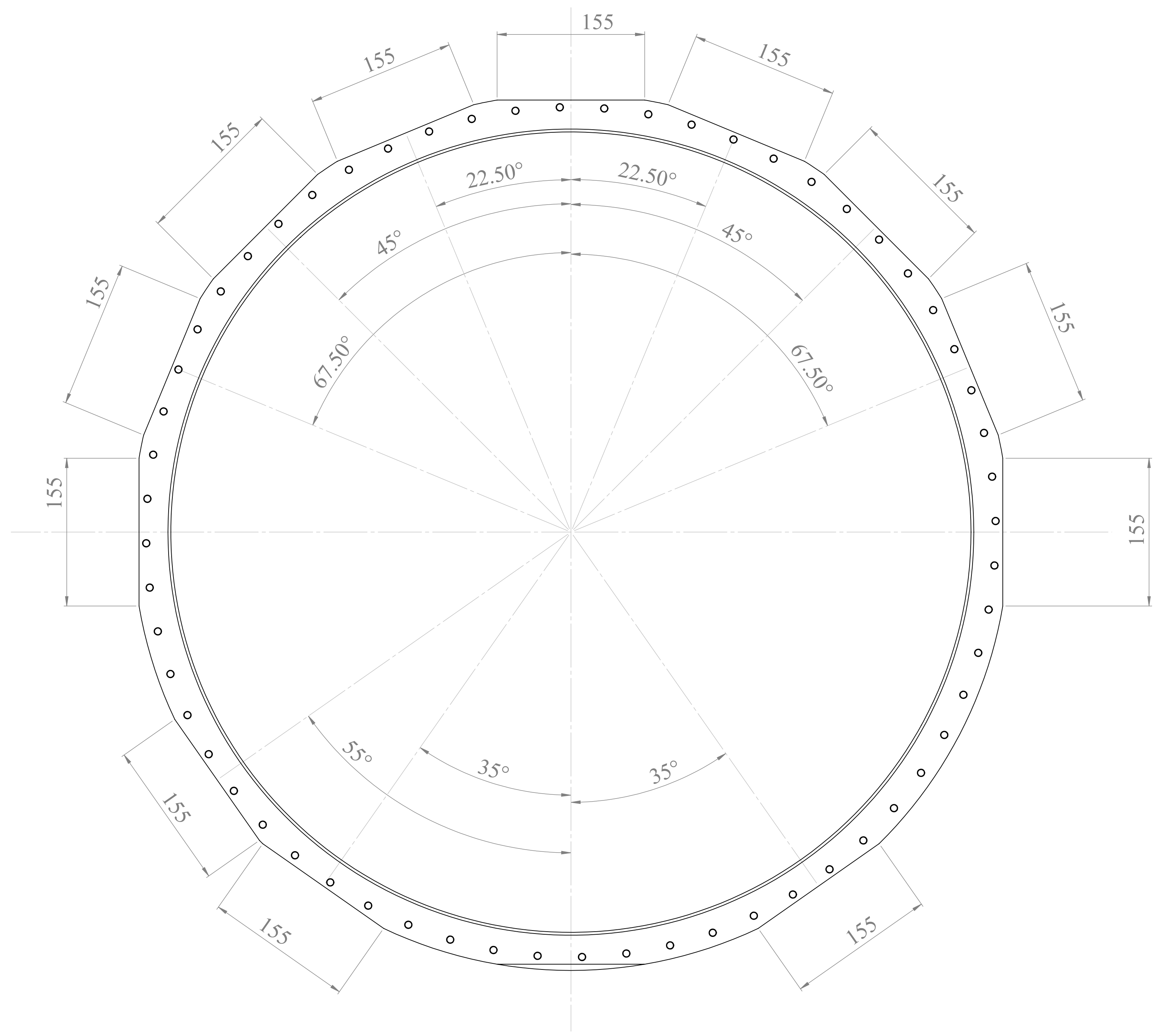

DRAWINGS FOR ESTIMATION PUPOSE ONLY

TOLERANCES: ONE PLACE DECIMAL ± 0.1mm TWO PLACE DECIMAL ± 0.02mm FRACTIONAL ± ANGULAR ± 0.02 deg.		DEBUR AND BREAK SHARP EDGES		ALL DIMENSIONS ARE IN MM		Inter University Accelerator Centre Formerly : Nuclear Science Centre New Delhi - 110067	
DRAWN	NAME	SIGNATURE	DATE			TITLE: VACUUM CHAMBER <i>Front View</i>	
CHKD						DWG NO. IUAC/HEBT/BUN /02 A1	
APPVD						MATERIAL: Qty : No.	
MFG						SCALE: 1:5 SHEET 2 OF 3 Rev - 1	
QA							

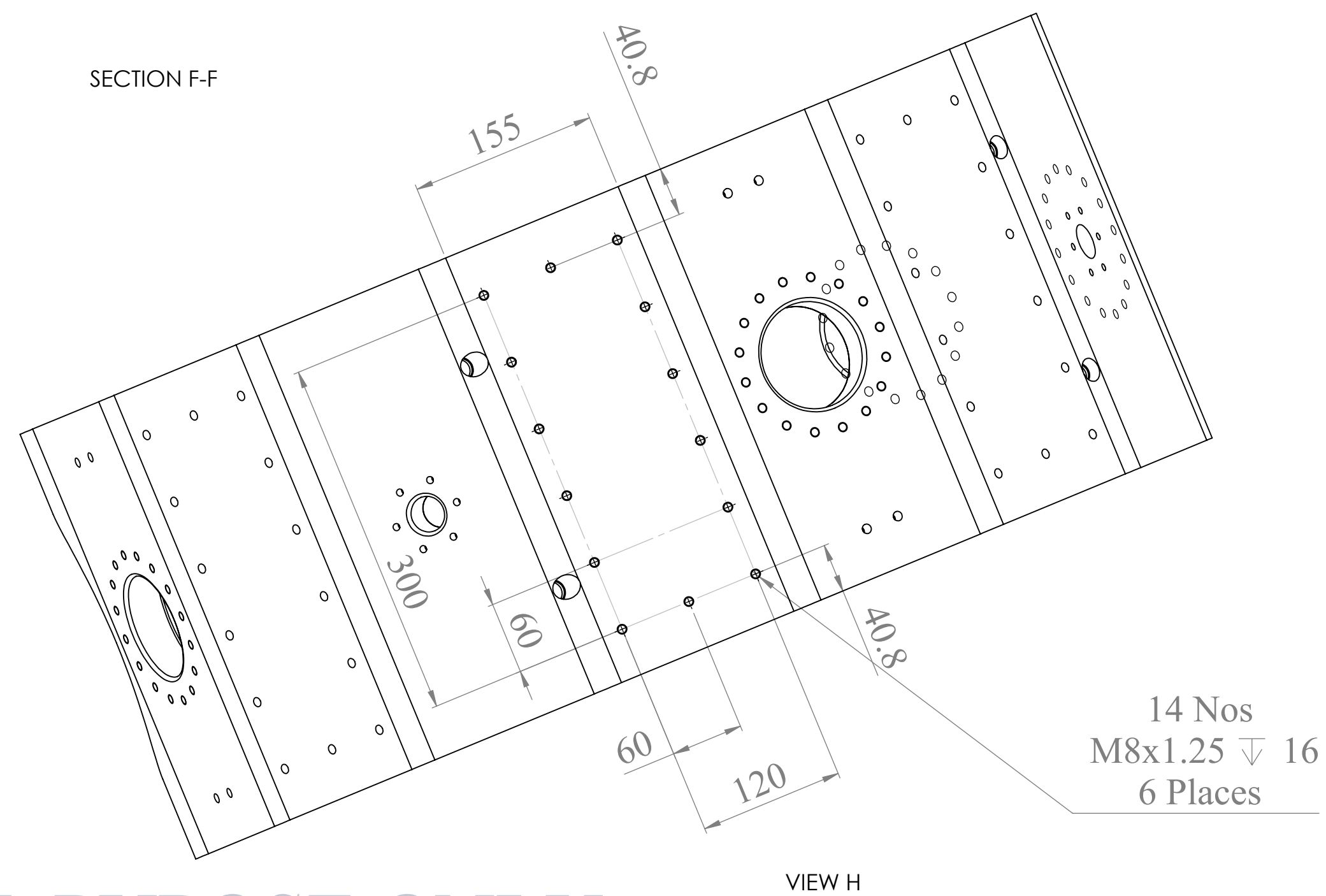
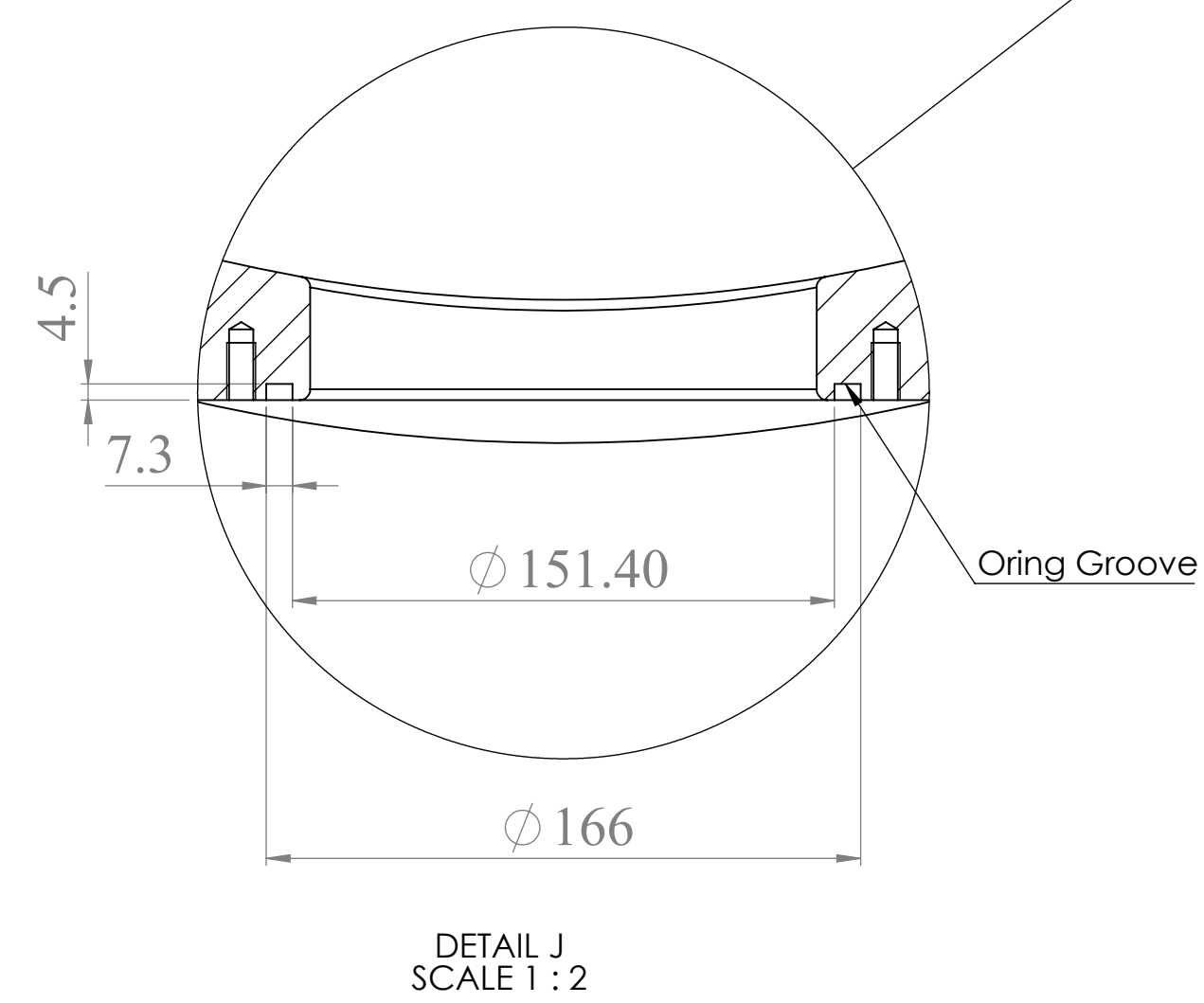
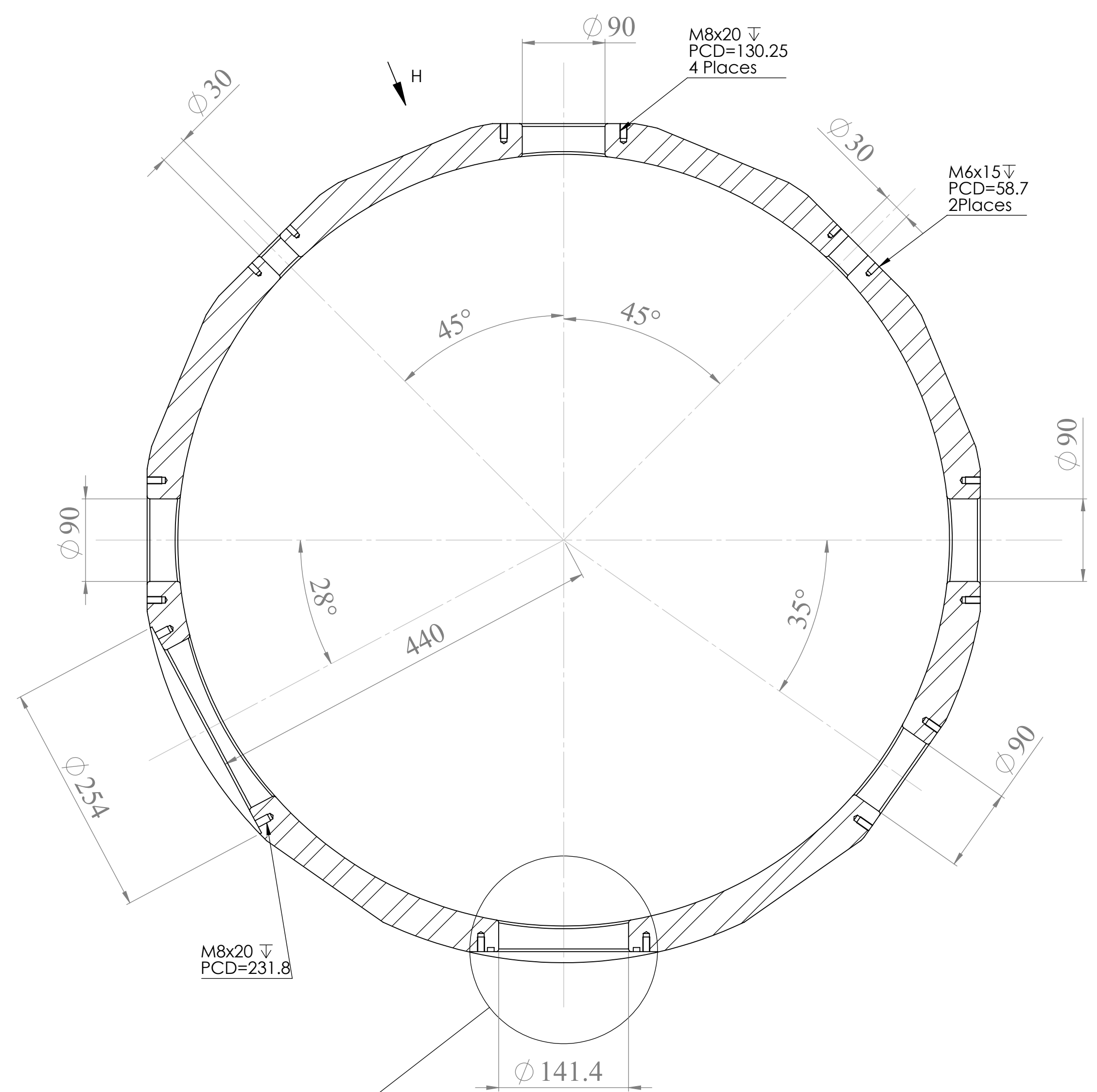
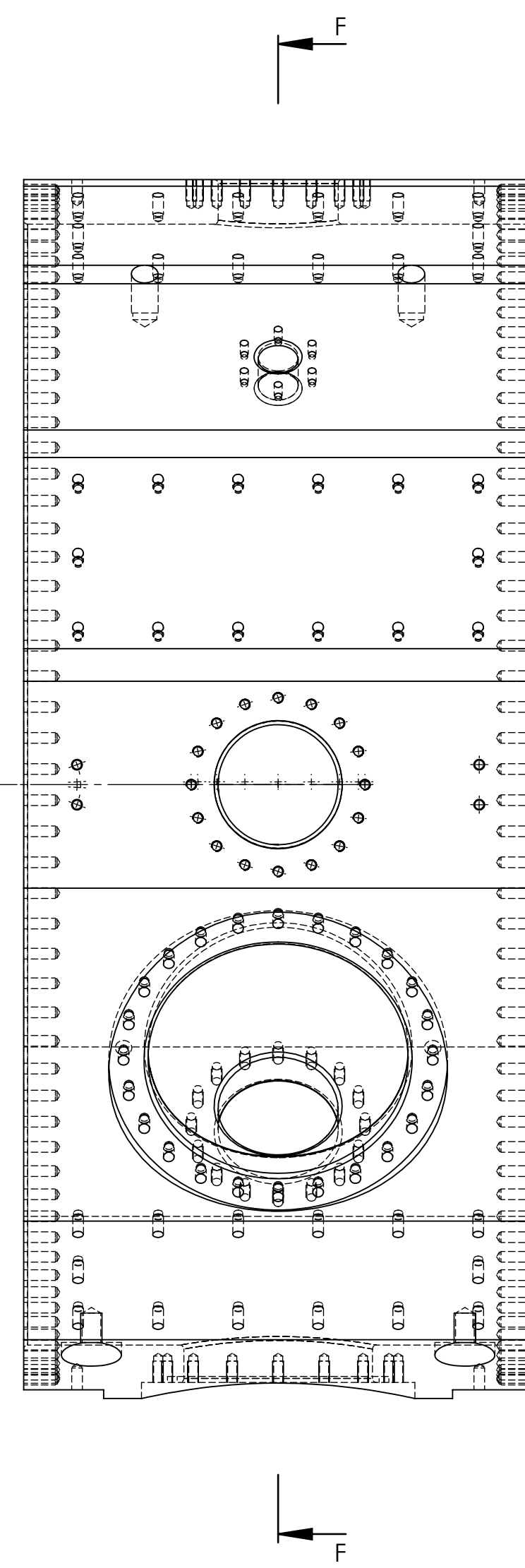

DRAWINGS FOR ESTIMATION PUPOSE ONLY

TOLERANCES				DEBUR AND BREAK SHARP EDGES	
ONE PLACE DECIMAL	TWO PLACE DECIMAL	FRACTIONAL	ANGULAR	ALL DIMENSIONS ARE IN MM	
± 0.1mm	± 0.02mm	±	± 0.02 deg		
DRAWN	NAME	SIGNATURE	DATE	TITLE: VACUUM CHAMBER	
CHKD				Sectional View	
APPVD				DWG NO. IUAC/HEBT/BUN /02	A1
MFG				SCALE: 1:5	SHEET 3 OF 3 Rev - 1
QA				MATERIAL: Qty : No.	
				WEIGHT:	

Inter University Accelerator Centre
Formerly : Nuclear Science Centre
New Delhi - 110067

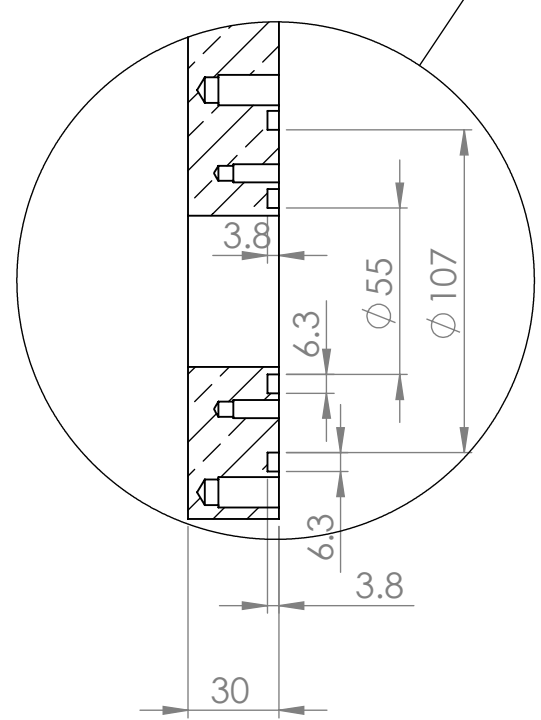
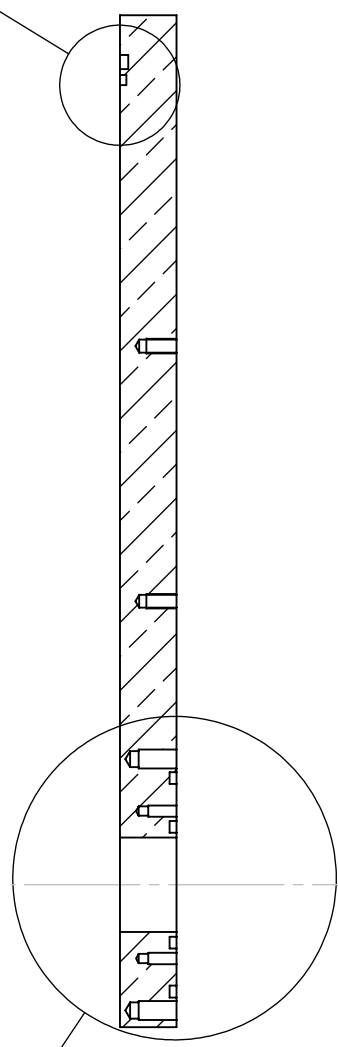
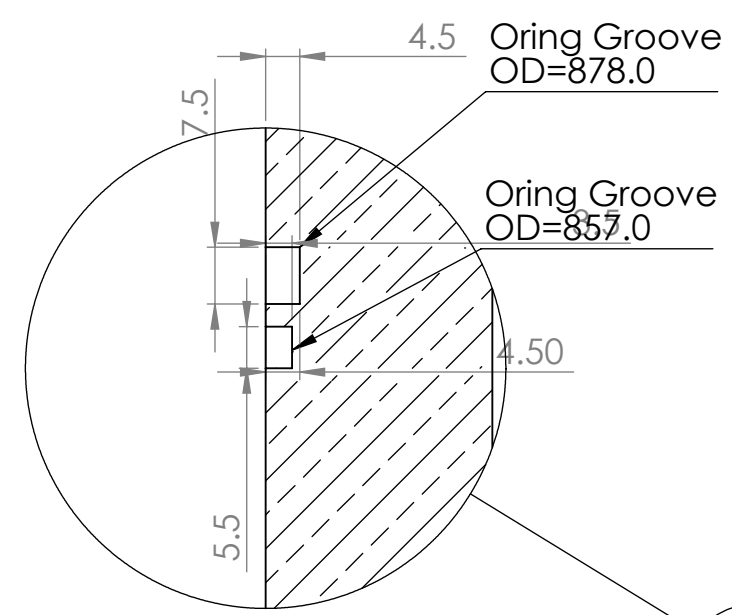
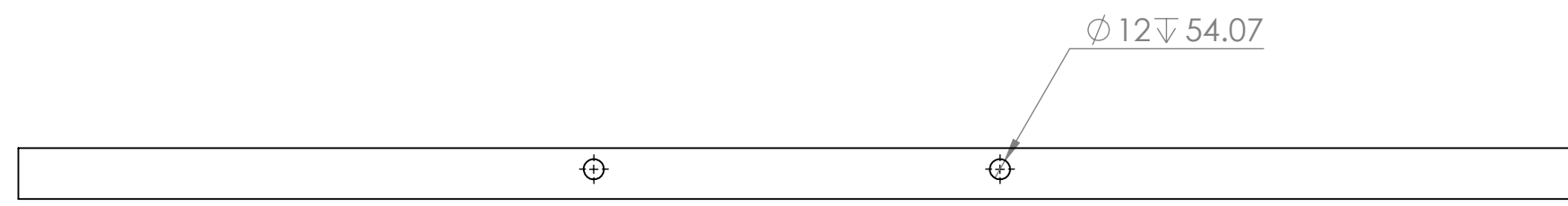

DETAIL D
SCALE 2 : 5

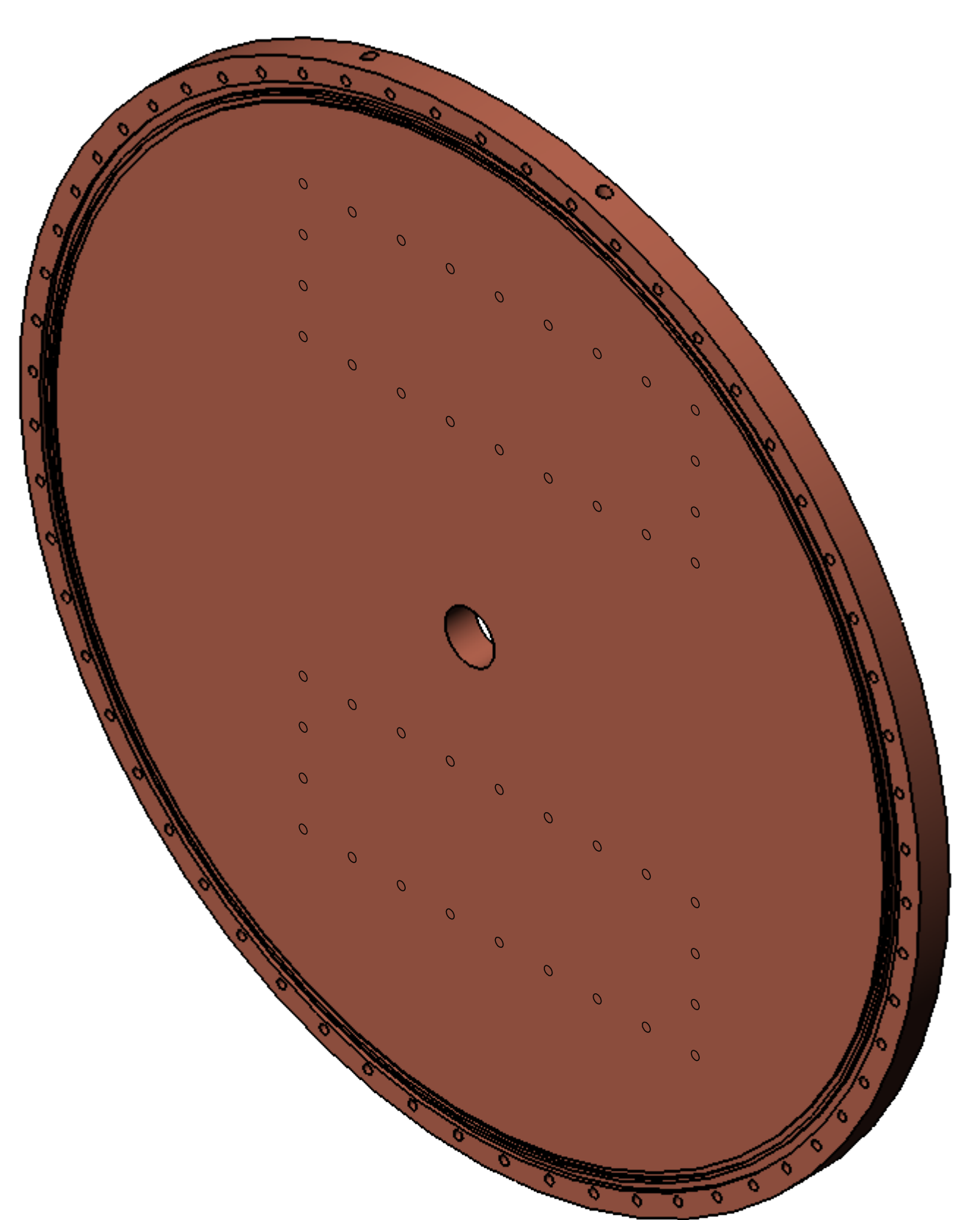
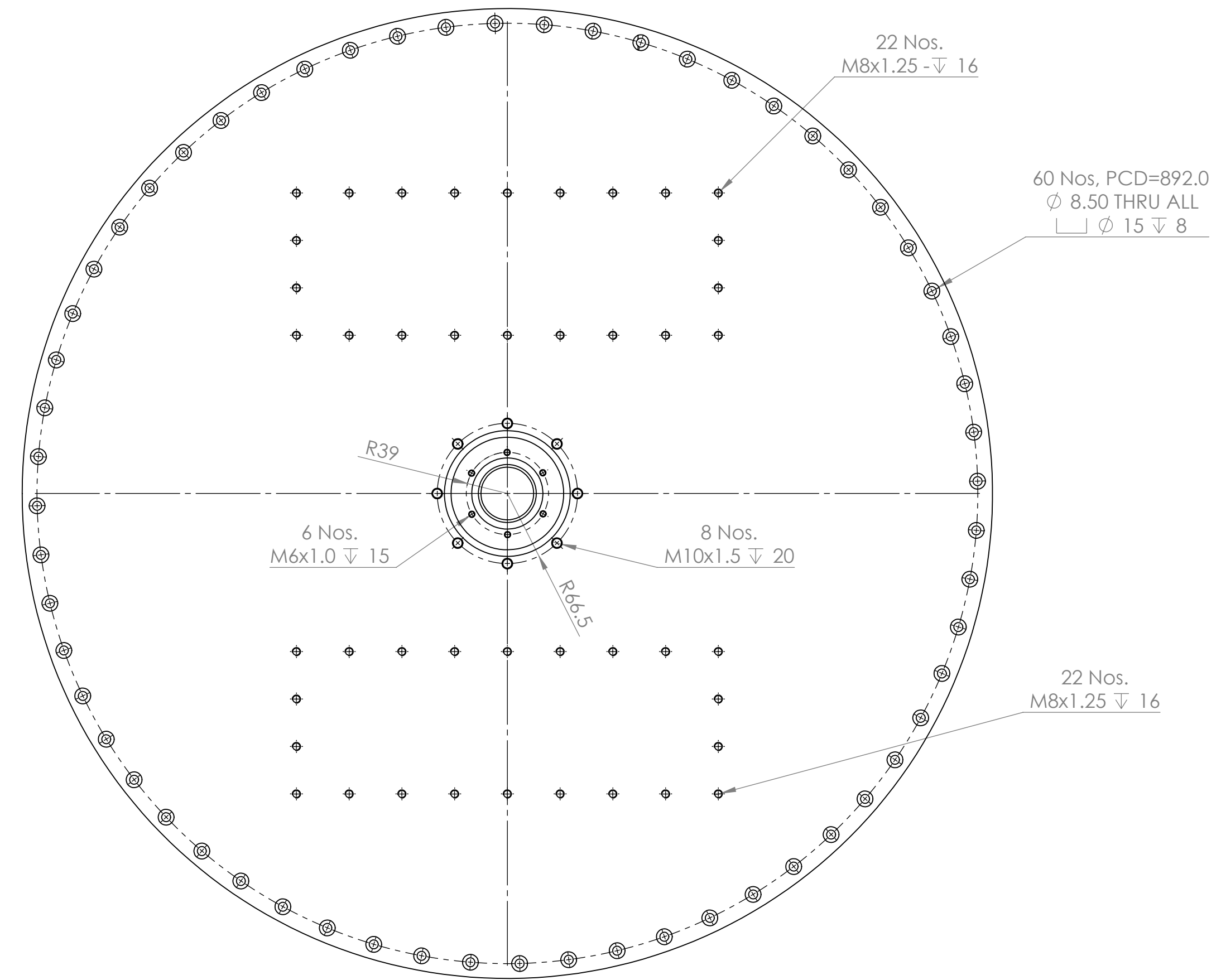
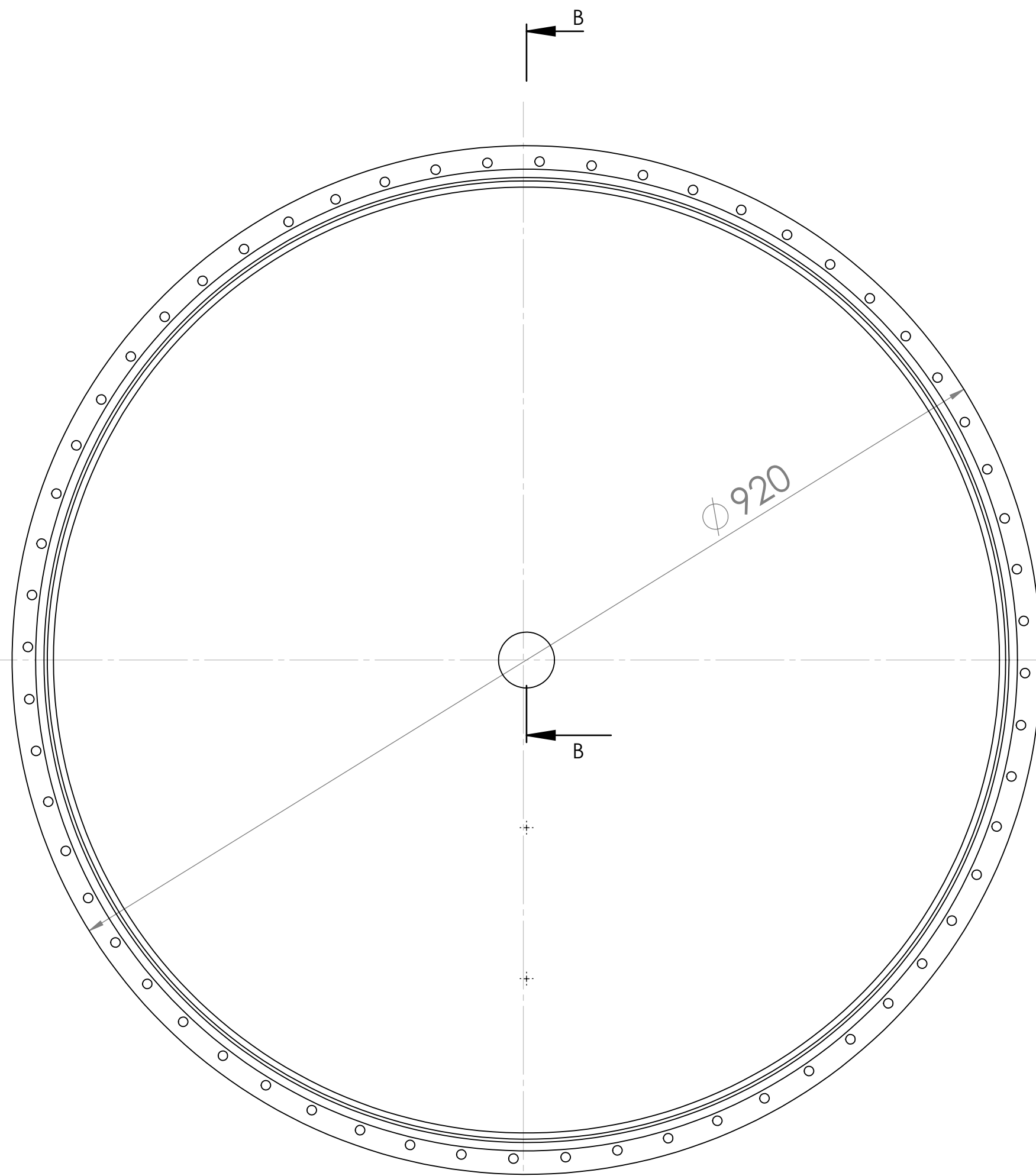

Note :

Raw material for End Plates will be provided by IUAC (OFHC copper 1000mmx1000mmx30-4nos.)

DRAWINGS FOR ESTIMATION PUPOSE ONLY

TOLERANCES:			DEBUR AND BREAK SHARP EDGES		
ONE PLACE DECIMAL	$\pm 0.1\text{mm}$		ALL DIMENSIONS ARE IN MM		
TWO PLACE DECIMAL	$\pm 0.02\text{mm}$				
FRACTIONAL	\pm				
ANGULAR	± 0.02 deg.				
DRAWN	SK	DATE	TITLE:		
CHKD	RA	23.3.21	END PLATE		
APPVD		23.3.21	DWG NO. IUAC/HEBT/BUN /03		
MFG			SCALE:1:5		
QA			SHEET 1 OF 1		
MATERIAL: IUAC Supplied OFHC Copper			A1		
Qty : 04 No.			Rev - 1		
WEIGHT:					

Inter University Accelerator Centre
Formerly : Nuclear Science Centre
New Delhi - 110067

DRAWING FOR ESTIMATION PURPOSE ONLY

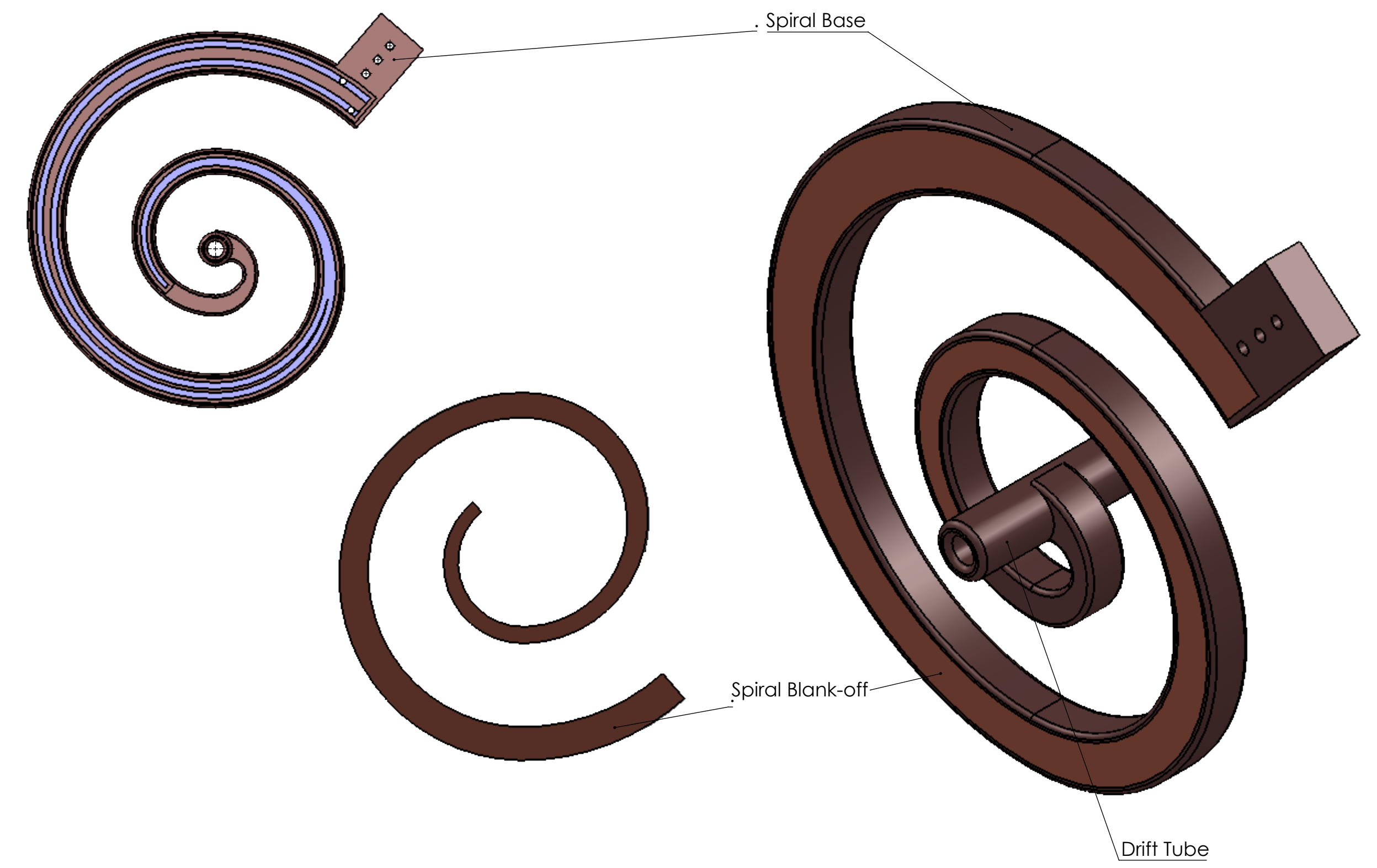

SECTION A-A
SCALE 1 : 2.5

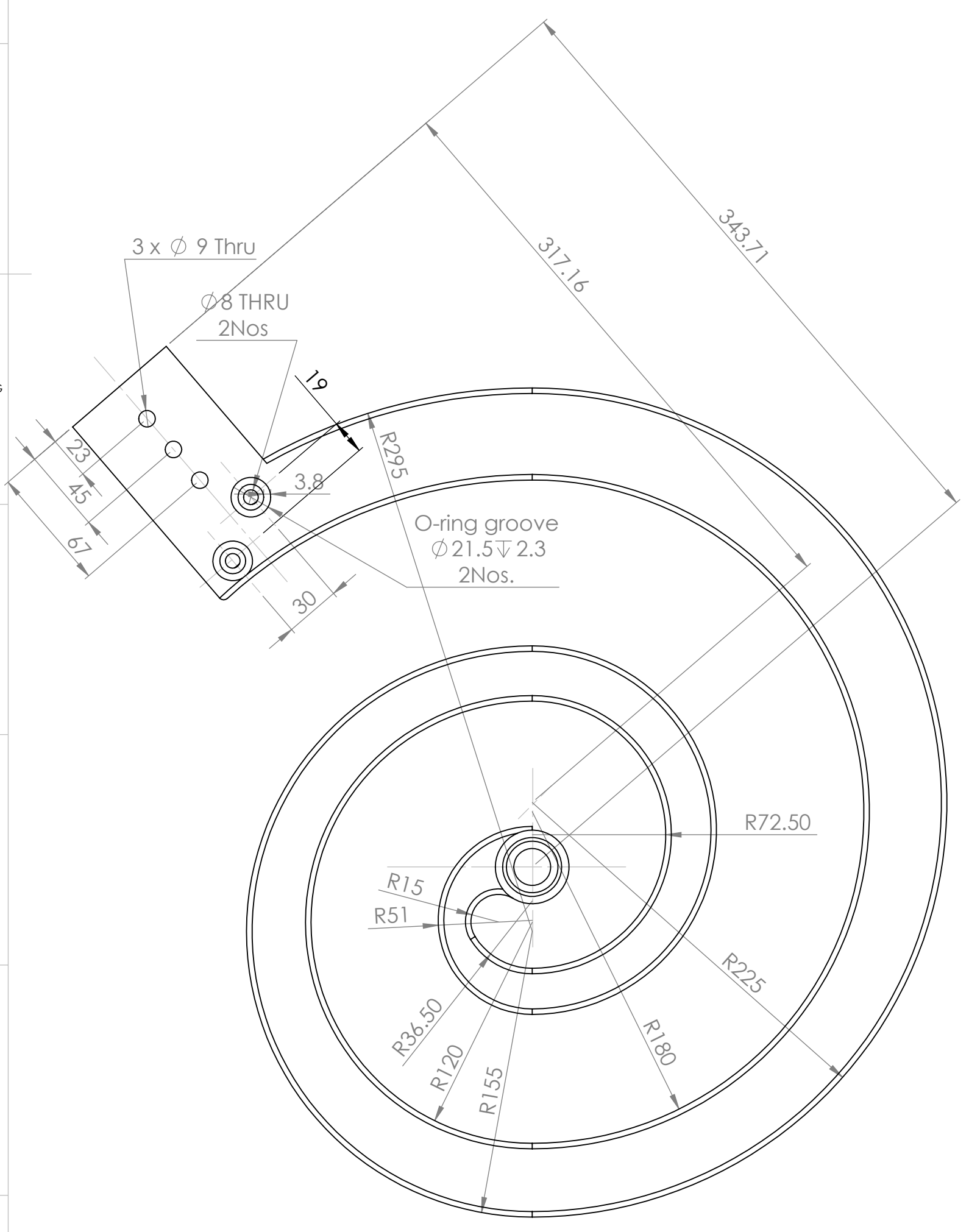
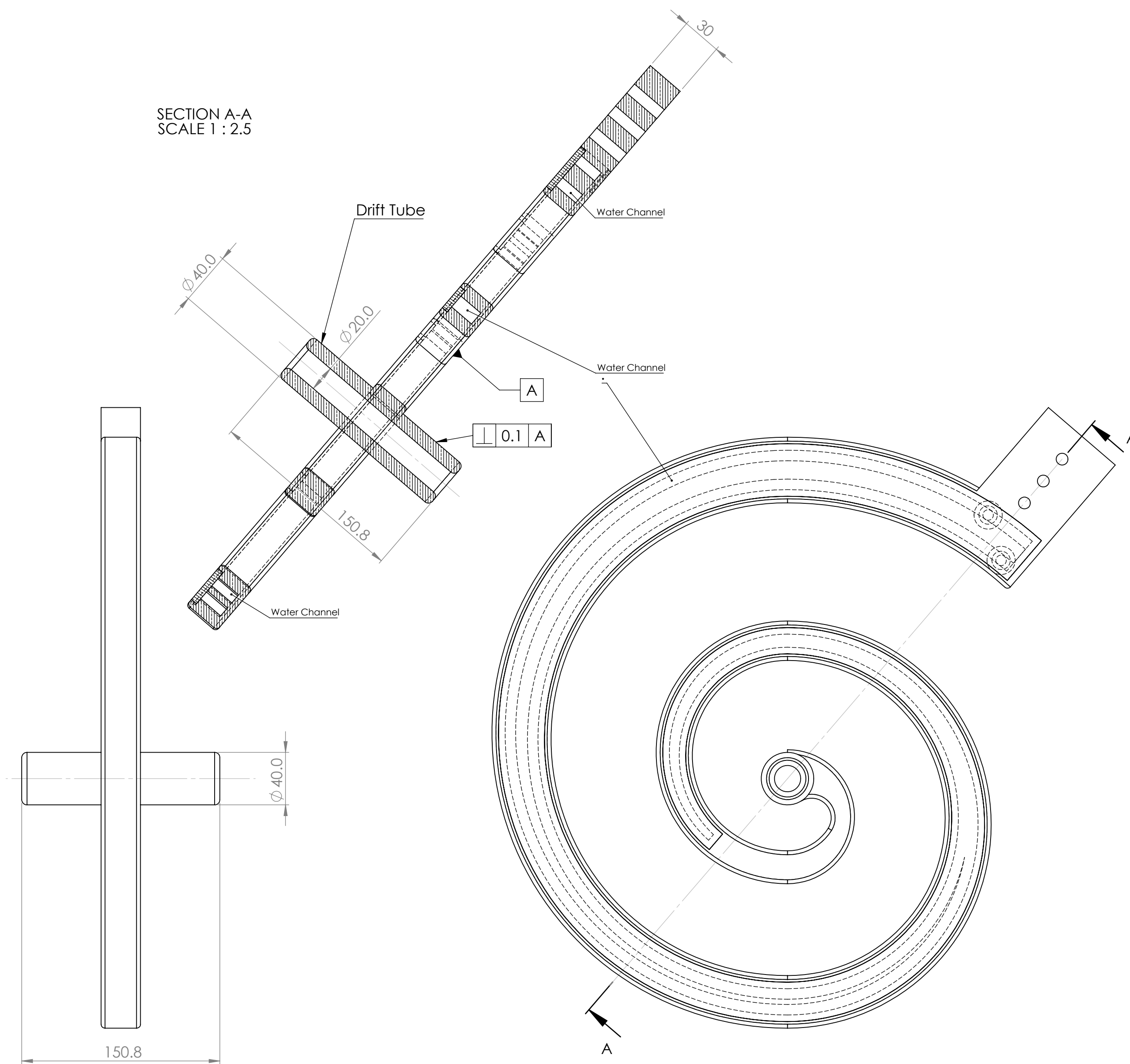

Note :

1. Only ETP (Cu - C11000) material to be used. IUAC will not supply the material.
2. Material test certificate for the material used has to be submitted. In addition test shall be conducted by IUAC on samples from completed components.
3. Spiral is made of two components i.e. Spiral Base and Spiral Blankoff. Spiral base is having water cooling channel in it and Spiral Blank off to be Vacuum Brazed with the spiral base to seal the cooling channels. The vendor should keep sufficient machining allowance to nullify the distortions with machining after brazing
4. Flatness and parallelism of the finished component to be maintained within an accuracy of ± 0.2 mm.
5. After welding, the finished component should be buffed and polished. No welding/brazing projection or depression should be visible. No sharp corners/edges are allowed. (Successful bidder may suggest any changes in the design to achieve this. Final responsibility will be of the bidder)
6. It will be better to keep machining allowance for machining after welding/brazing.
7. Components model drawing can be provided to vendor in "iges" formats.
8. Vendor will be required to submit CMM report, Hydrostatic pressure test report up to 5 bar pressure & Vacuum Leak test report of the finished component.
9. **Workmanship** :- The supplied components should have excellent workmanship in all the aspects of fabrication.
10. Vacuum Testing :- Since the spiral is having water cooling channel and welding joints, therefore the vacuum Leak test report should be sent to IUAC before dispatch. The spiral component will also be subjected to leak testing at IUAC after delivery and the helium leak rate should be better than 1×10^{-9} mbar lt/sec.
11. Vendor may have to design and fabricate vacuum leak testing fixture. The spiral component will be vacuum leak tested individually as well as after assembling it inside the vacuum chamber with water flowing at 5bar pressure.
12. Drift tube may be laser welded with Spiral for good electrical contact and Welding strength

Gen. TOLERANCES:

ONE PLACE DECIMAL ± 0.1 mm
 TWO PLACE DECIMAL ± 0.02 mm
 WITHOUT DECIMAL ± 0.5 mm
 ANGULAR: ± 0.20 deg.

PROPRIETARY AND CONFIDENTIAL

THE INFORMATION CONTAINED IN THIS DRAWING IS THE SOLE PROPERTY OF IUAC, New Delhi.
 ANY REPRODUCTION, IN PART OR AS A WHOLE, WITHOUT THE WRITTEN PERMISSION OF IUAC, IS PROHIBITED.

ALL DIMENSIONS ARE IN MM

NAME	SIGNATURE	DATE
DRAWN		23.03.21
CHKD		
APPVD		
MFG		
G.A.		

MATERIAL: ETP Cu
 Cu - C11000
 Qty. : 02 Nos.

DESIGN AND BREAK SHARP EDGES

Inter University Accelerator Centre
 Formerly : Nuclear Science Centre
 New Delhi - 110067

TITLE:
 SPIRAL (Cu)

DWG NO :
 IUAC/HEBT/BUN /04

A1

SCALE: 1:2

SHEET 1 OF 1

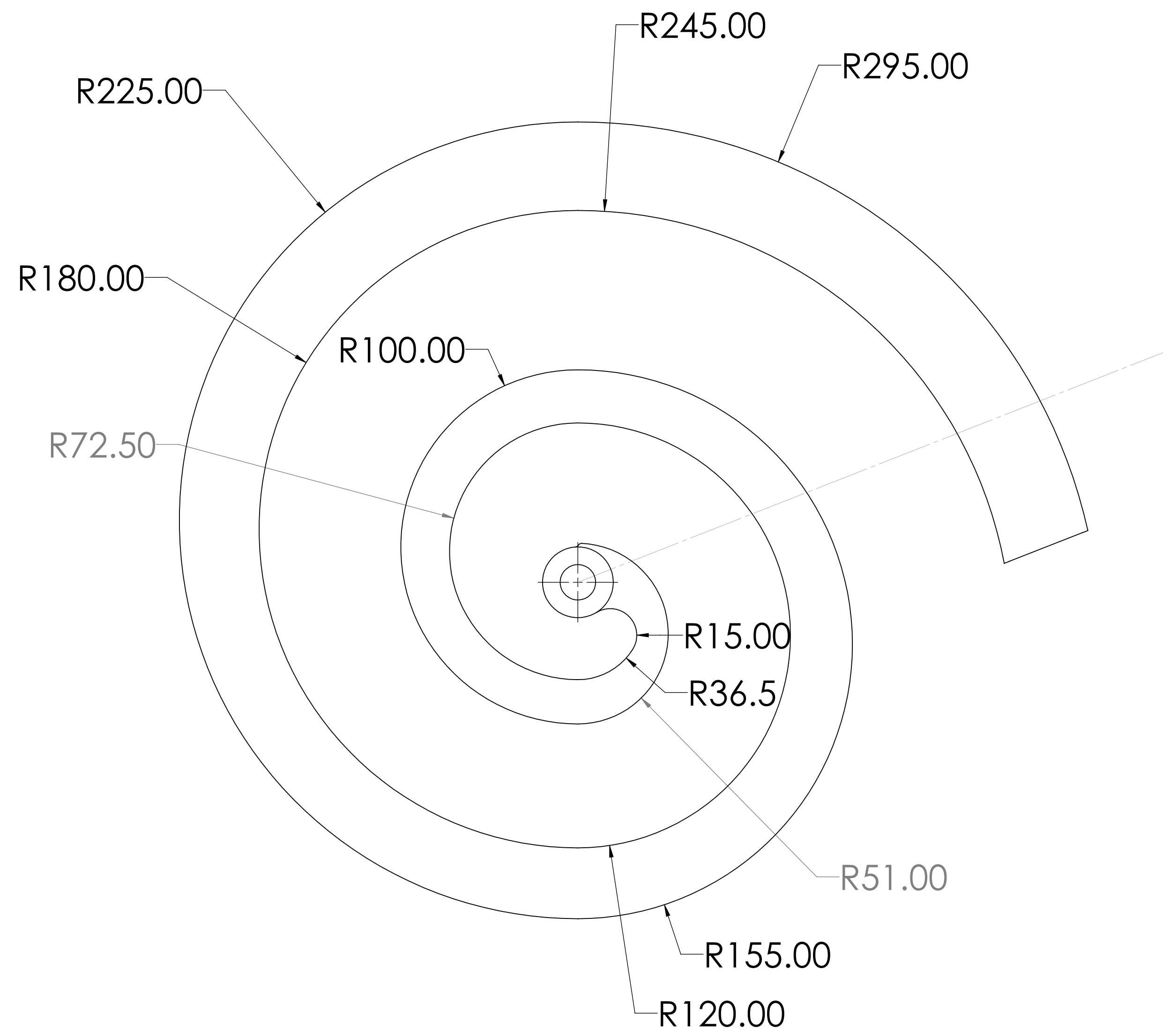
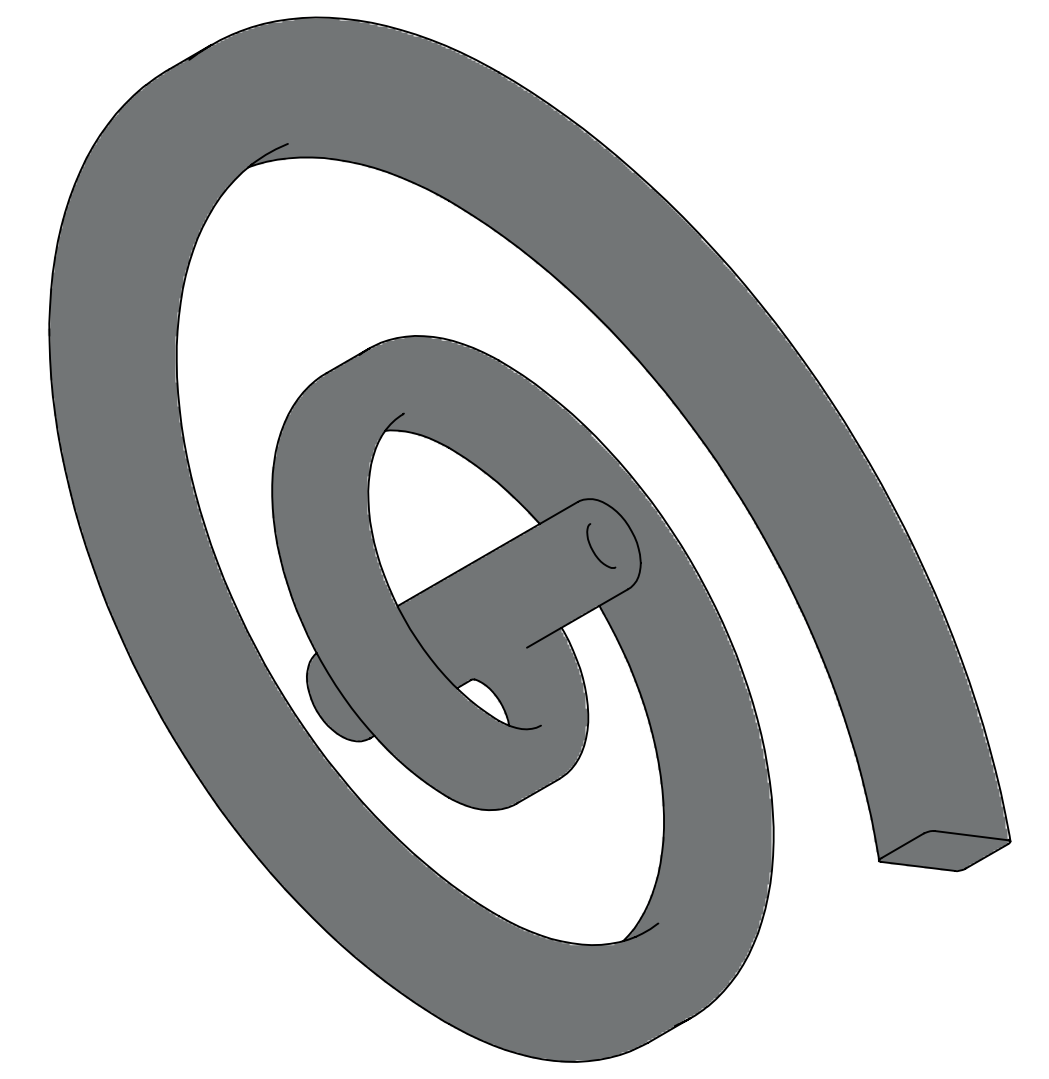
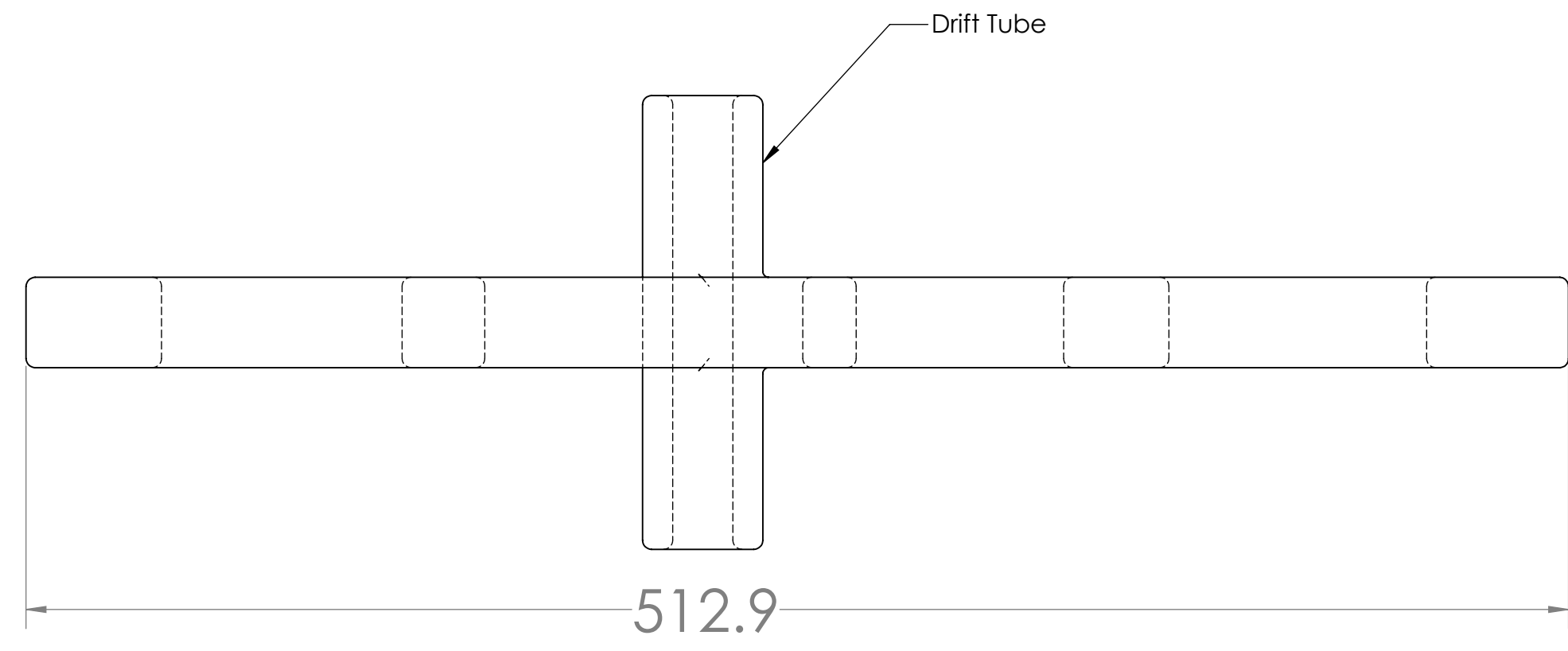
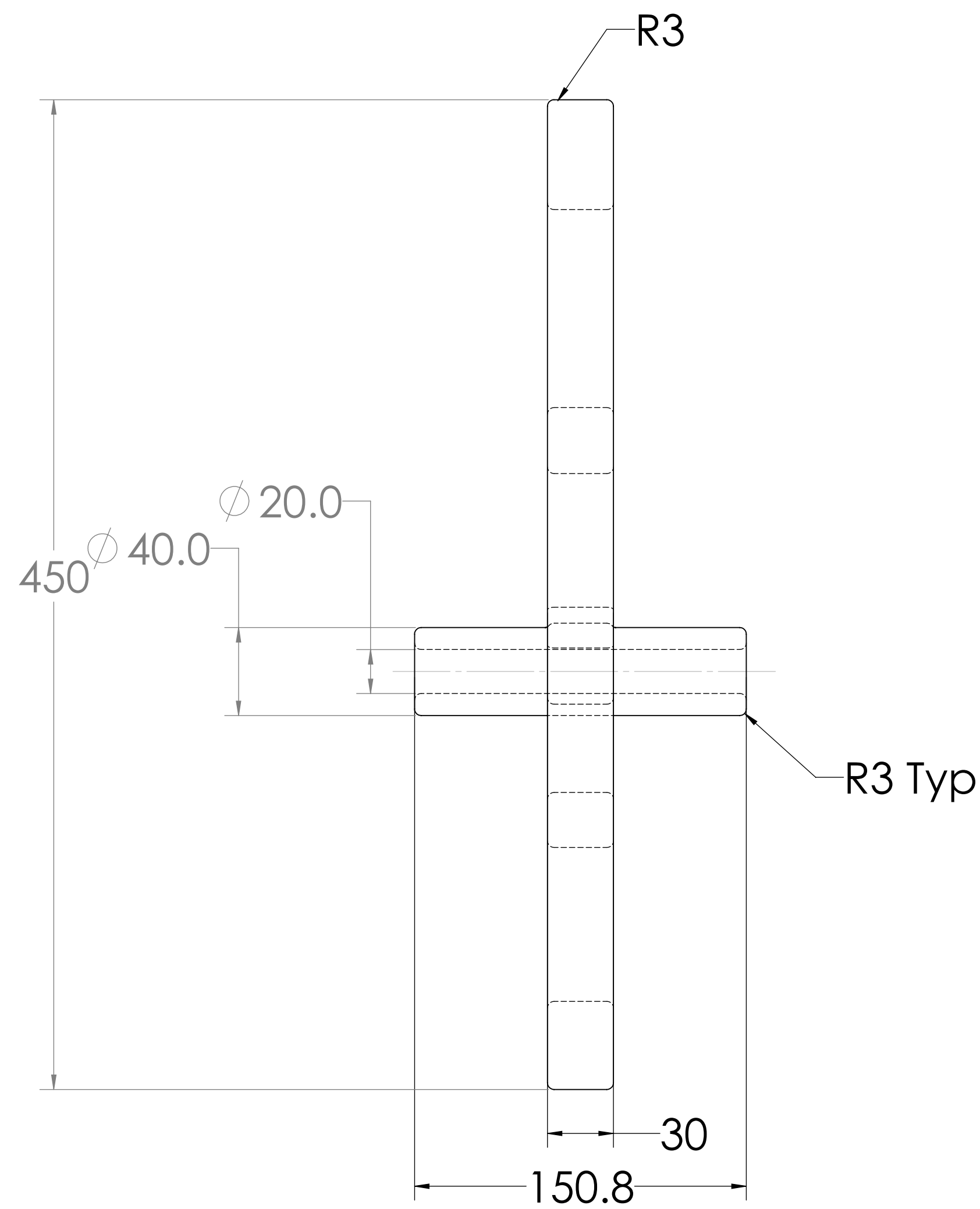

Note :

1. Flatness and parallelism of the finished component to be maintained within an accuracy of ± 0.2 mm.
2. Components model drawing can be provided to vendor in "iges" formats.
3. Vendor will be required to submit CMM report of the finished component.
4. Drift Tube may be welded / brazed (laser welded) for good electrical contact and mechanical strength.

DRAWINGS FOR ESTIMATION PUPOSE ONLY

Gen. TOLERANCES:

ONE PLACE DECIMAL ± 0.1 mm
 TWO PLACE DECIMAL ± 0.02 mm
 WITHOUT DECIMAL ± 0.5 mm
 ANGULAR: ± 0.20 deg.

PROPRIETARY AND CONFIDENTIAL

THE INFORMATION CONTAINED IN THIS DRAWING IS THE SOLE PROPERTY OF IUAC, New Delhi.
 ANY REPRODUCTION, IN PART OR AS A WHOLE, WITHOUT THE WRITTEN PERMISSION OF IUAC, IS PROHIBITED.

ALL DIMENSIONS ARE IN MM

DESUR AND BREAK SHARP EDGES

Inter University Accelerator Centre
 Formerly : Nuclear Science Centre
 New Delhi - 110067

NAME	SIGNATURE	DATE
DRAWN: DKP		06/12/19
CHKD:		
APPVD: RA		23.3.21
MFG:		
G.A:		

TITLE:

Aluminium SPIRAL

DWG NO : IUAC/HEBT/BUN /05

MATERIAL: Aluminium

Qty. : 02 Nos.

A1

SCALE: 1:2 SHEET 1 OF 1

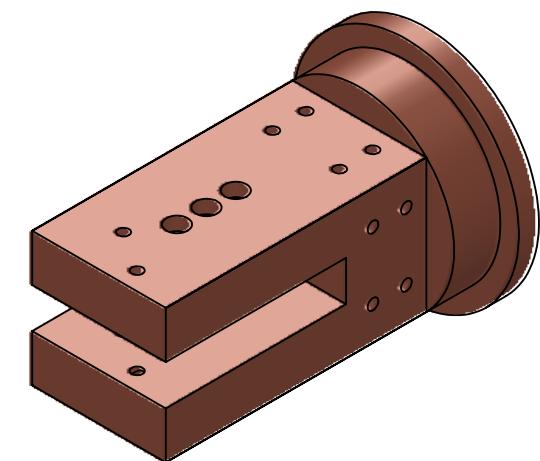
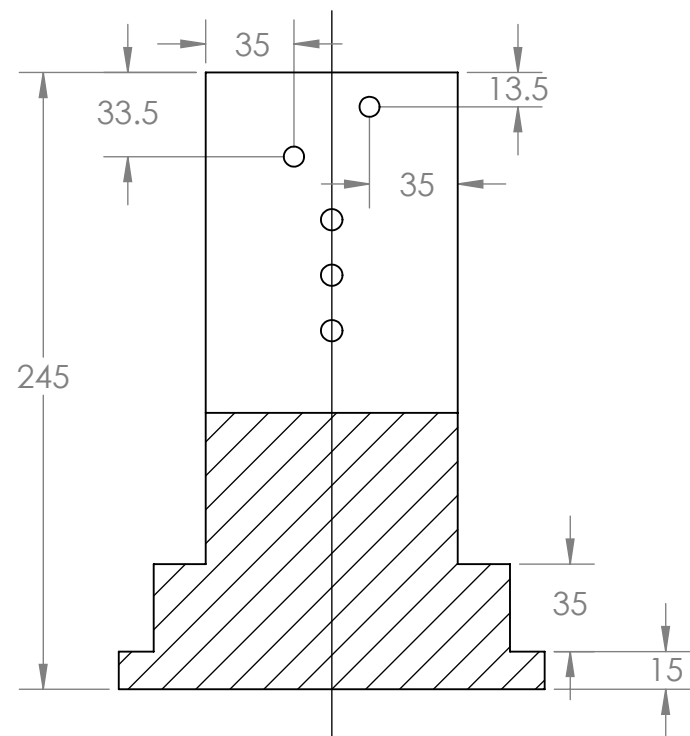

Drawing for Estamition Purpose Only

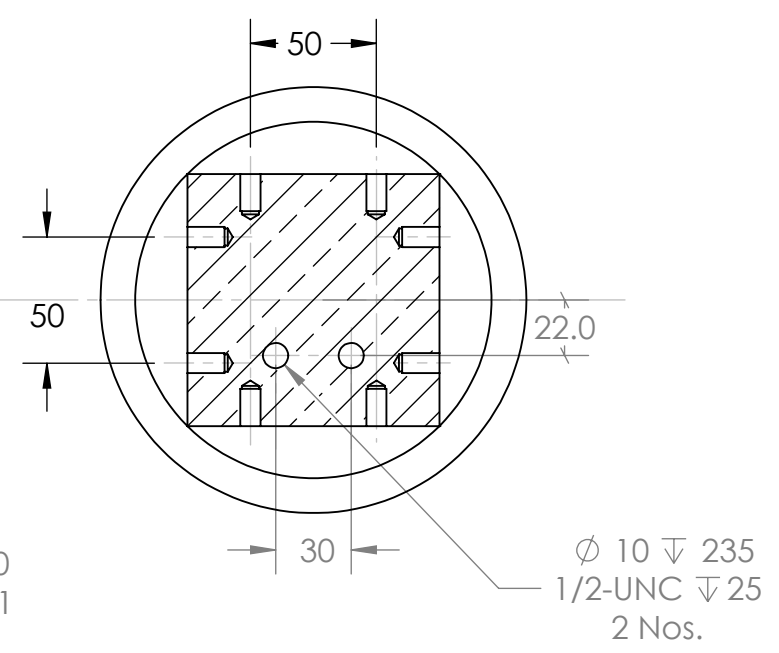
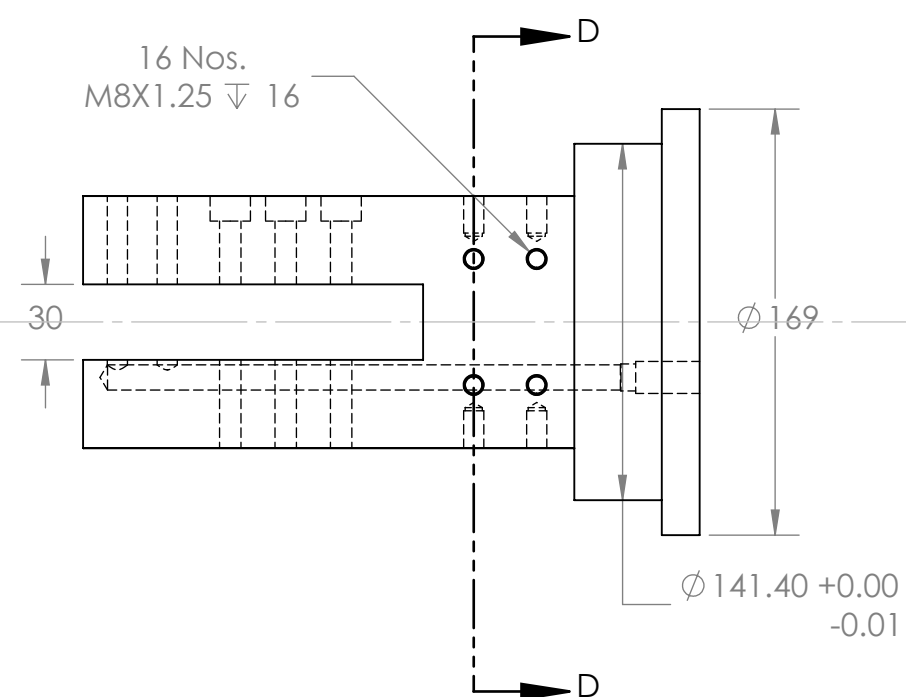
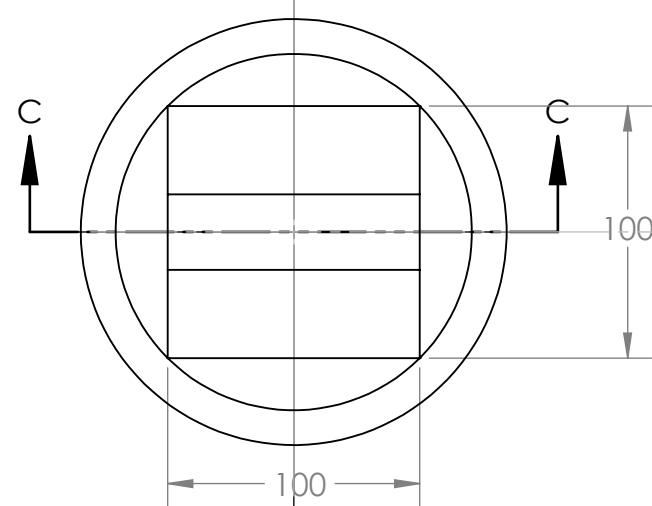

SECTION D-D
SCALE 1 : 3

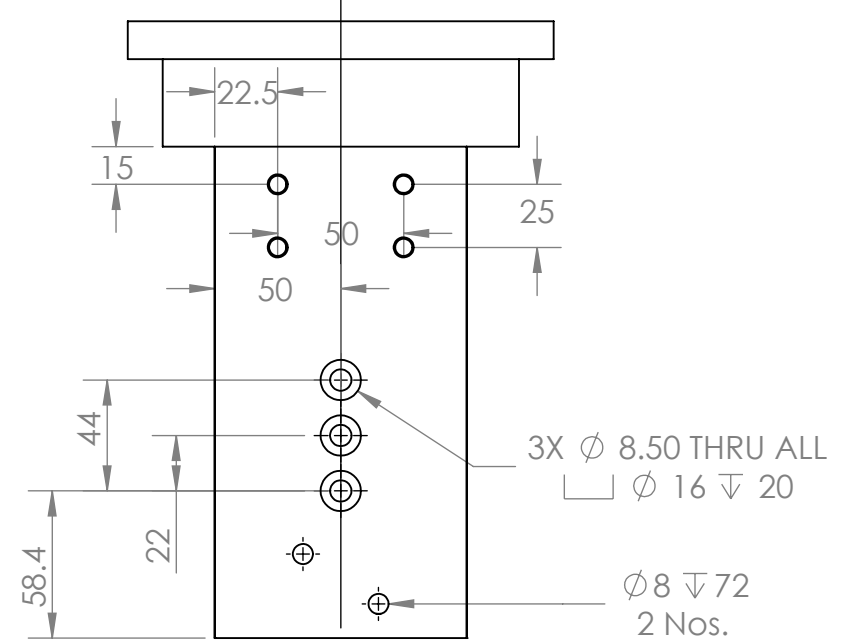

UNLESS OTHERWISE SPECIFIED: DIMENSIONS ARE IN MILLIMETERS		FINISH:		DEBURR AND BREAK SHARP EDGES		DO NOT SCALE DRAWING		REVISION	
SURFACE FINISH:									
TOLERANCES:									
LINEAR:									
ANGULAR:									
DRAWN		NAME		SIGNATURE		DATE		TITLE:	
CHK'D		DKP				23.3.21		SPIRAL POST (Cu)	
APPV'D									
MFG									
Q.A									
				Material :		ETP-Cu		DWG NO.	
						C-11000		IUAC/ HEBT/BUN /06	
				Qty. :		:02 Nos.		A3	
				WEIGHT:				SCALE:1:5	

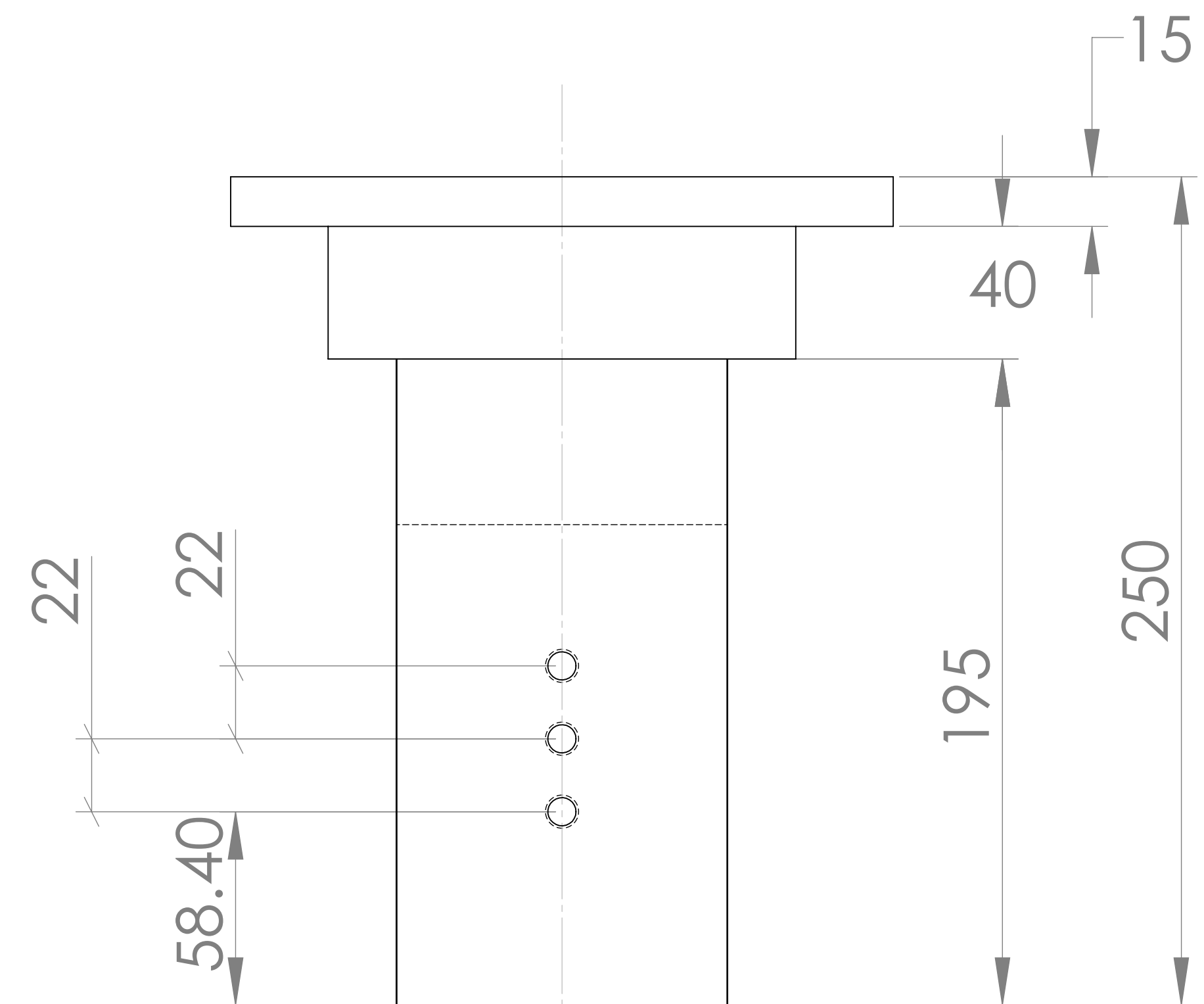
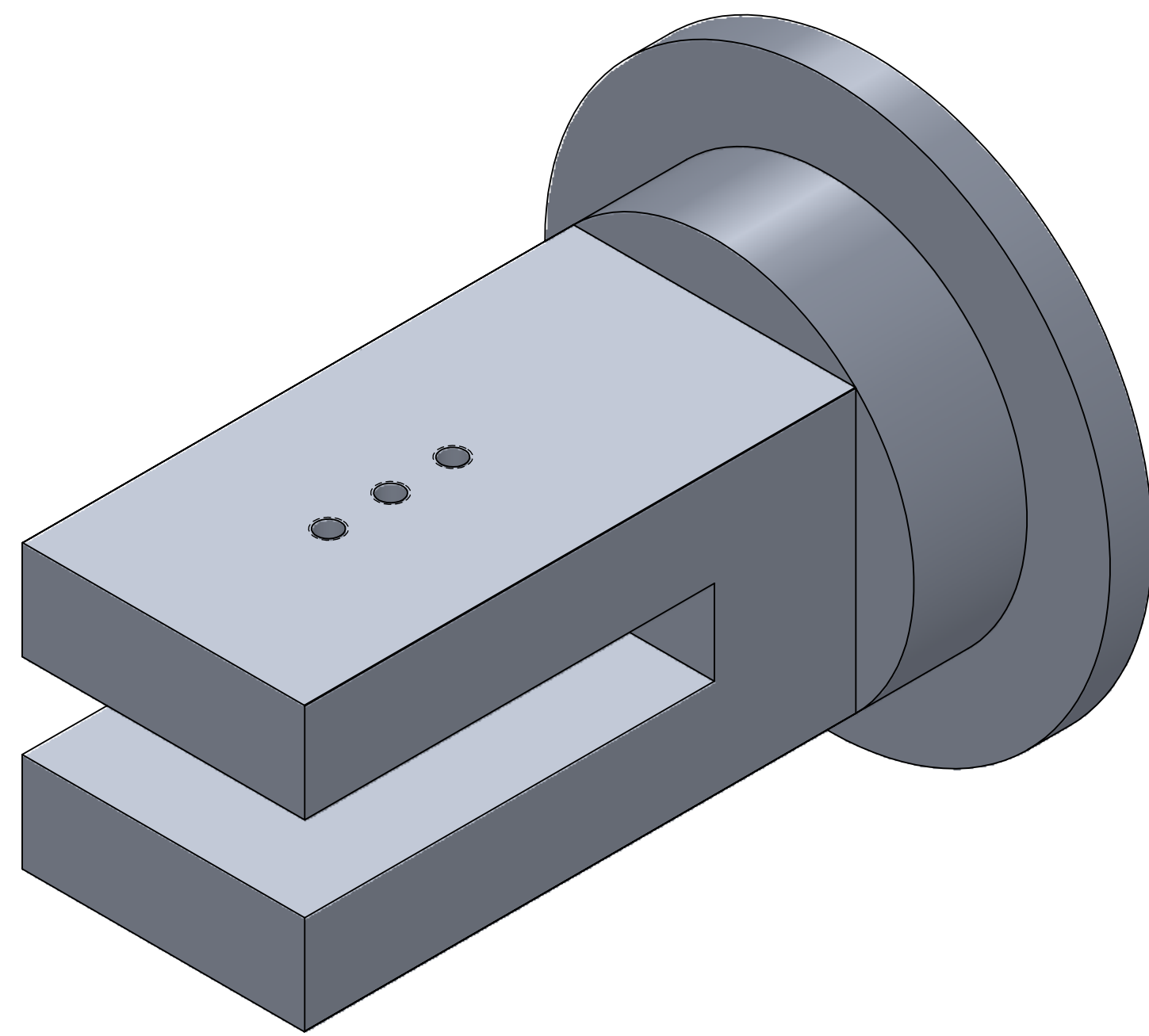

DRAWINGS FOR ESTIMATION PUPOSE ONLY

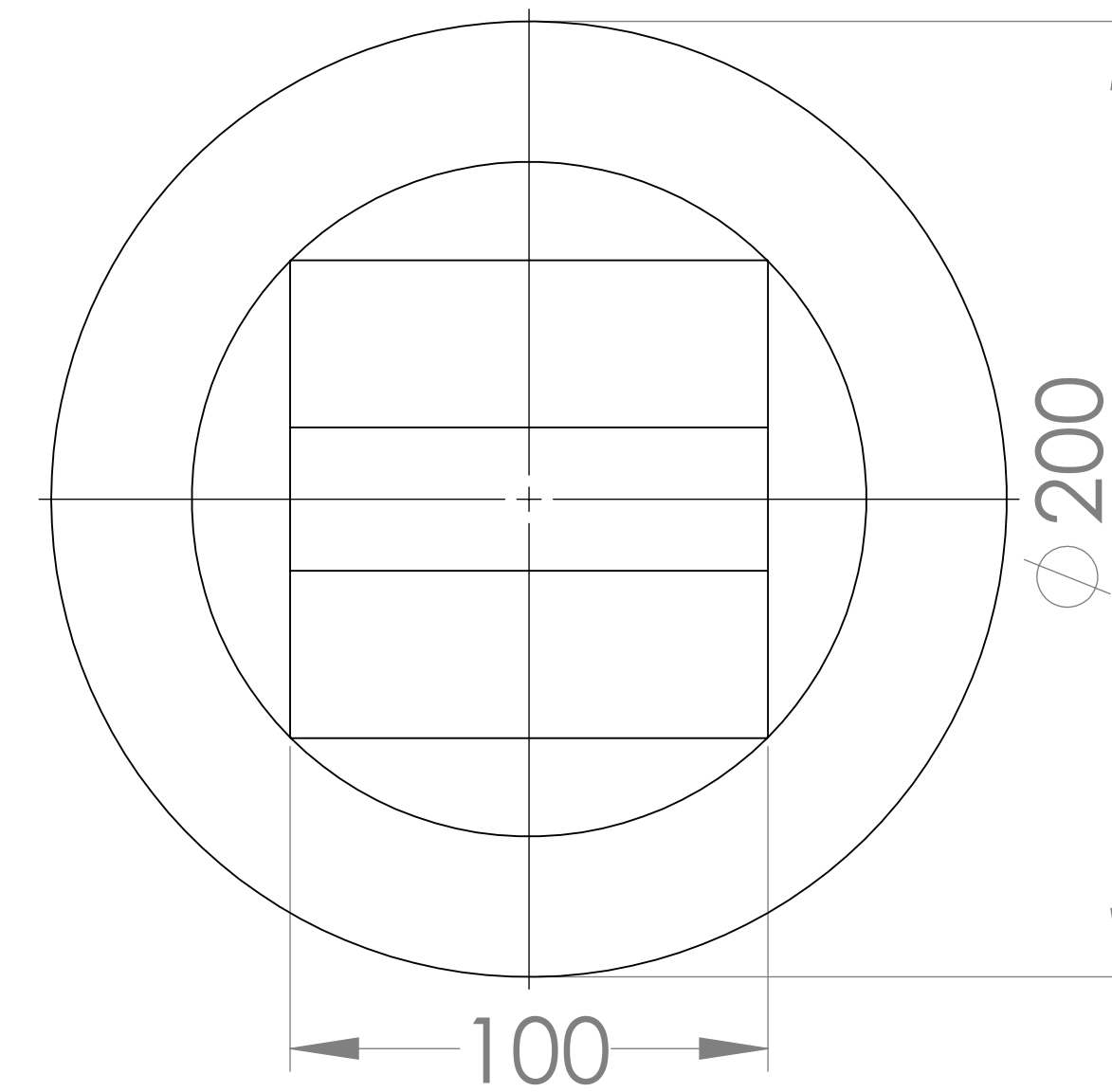
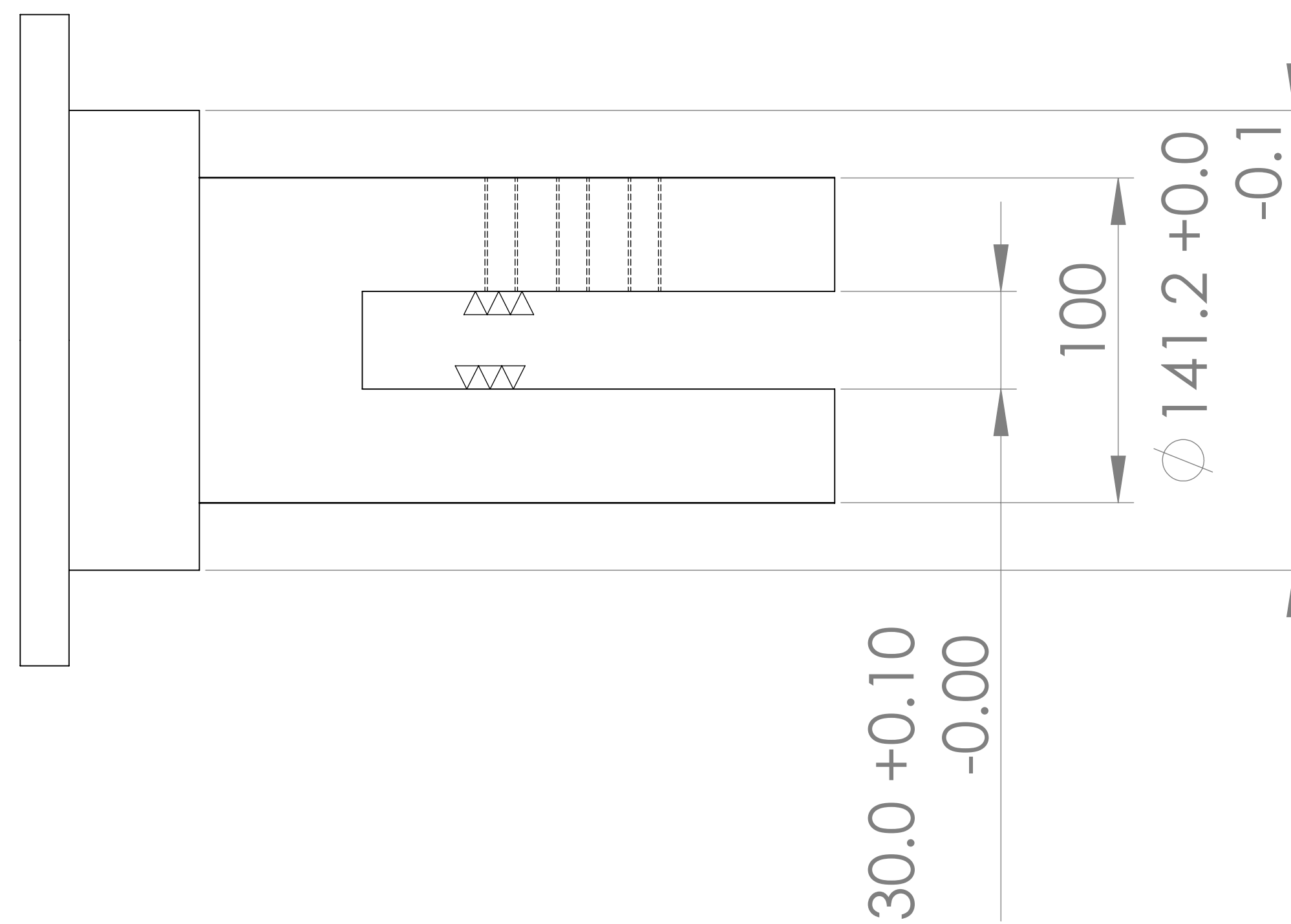

Gen. TOLERANCES:

ONE PLACE DECIMAL ± 0.1mm
 TWO PLACE DECIMAL ± 0.02mm
 WITHOUT DECIMAL ± 0.5mm

ANGULAR: ± 0.20 deg.

PROPRIETARY AND CONFIDENTIAL

THE INFORMATION CONTAINED IN THIS DRAWING IS THE SOLE PROPERTY OF IUAC, New Delhi.

ANY REPRODUCTION, IN PART OR AS A WHOLE, WITHOUT THE WRITTEN PERMISSION OF IUAC, IS PROHIBITED.

ALL DIMENSIONS ARE IN MM

DESIR AND BREAK SHARP EDGES

Inter University Accelerator Centre
 Formerly : Nuclear Science Centre
 New Delhi - 110067

	NAME	SIGNATURE	DATE
DRAWN	DKP		23.3.21
CHKD			
APPVD	RA		23.3.21
QA			
MFG			

TITLE:

SPIRAL POST (AL)

DWG NO : IUAC/ HEBT/BUN /07

MATERIAL: Aluminium

Qty. : 02 Nos.

SCALE: 1:2

SHEET 1 OF 1

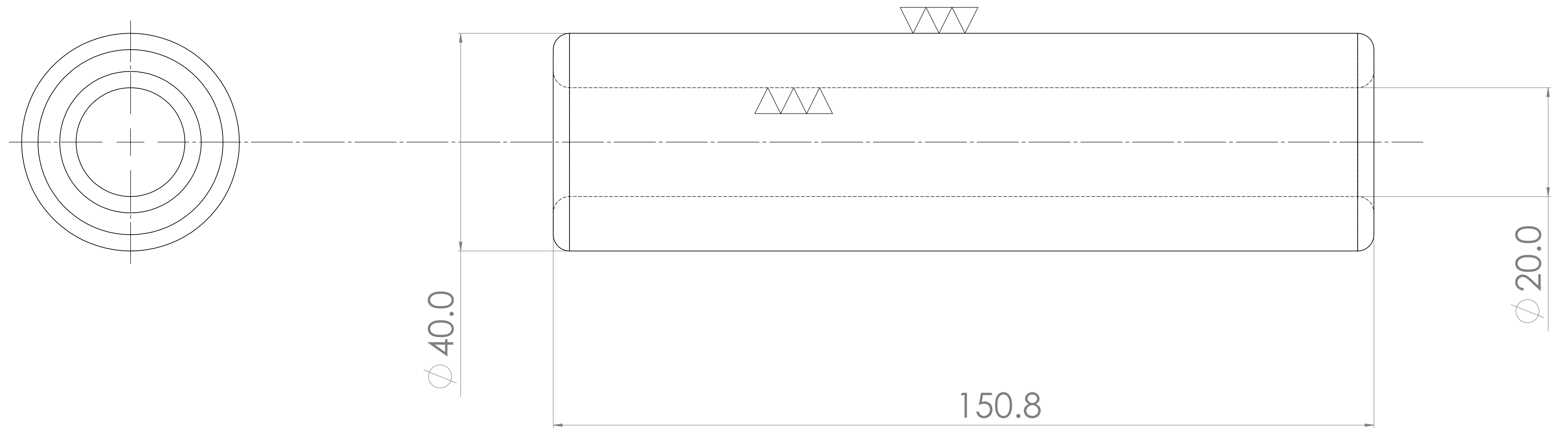

DRAWINGS FOR ESTIMATION PUPOSE ONLY

Gen. TOLERANCES:

ONE PLACE DECIMAL ± 0.1mm
 TWO PLACE DECIMAL ± 0.02mm
 WITHOUT DECIMAL ± 0.5mm
 ANGULAR: ± 0.20 deg.

PROPRIETARY AND CONFIDENTIAL

THE INFORMATION CONTAINED IN THIS DRAWING IS THE SOLE PROPERTY OF IUAC, New Delhi.
 ANY REPRODUCTION, IN PART OR AS A WHOLE, WITHOUT THE WRITTEN PERMISSION OF IUAC, IS PROHIBITED.

ALL DIMENSIONS ARE IN MM

DESIR AND BREAK SHARP EDGES

Inter University Accelerator Centre
 Formerly : Nuclear Science Centre
 New Delhi - 110067

	NAME	SIGNATURE	DATE
DRAWN	SK		23.3.21
CHKD			
APPVD	RA		
MFG			
G.A			

TITLE: Central Drift Tube

MATERIAL:
 ETP Cu - 02 Nos.
 Qty. : Aluminium - 02 Nos

DWG NO : IUAC/ HEBT/BUN /8

A1

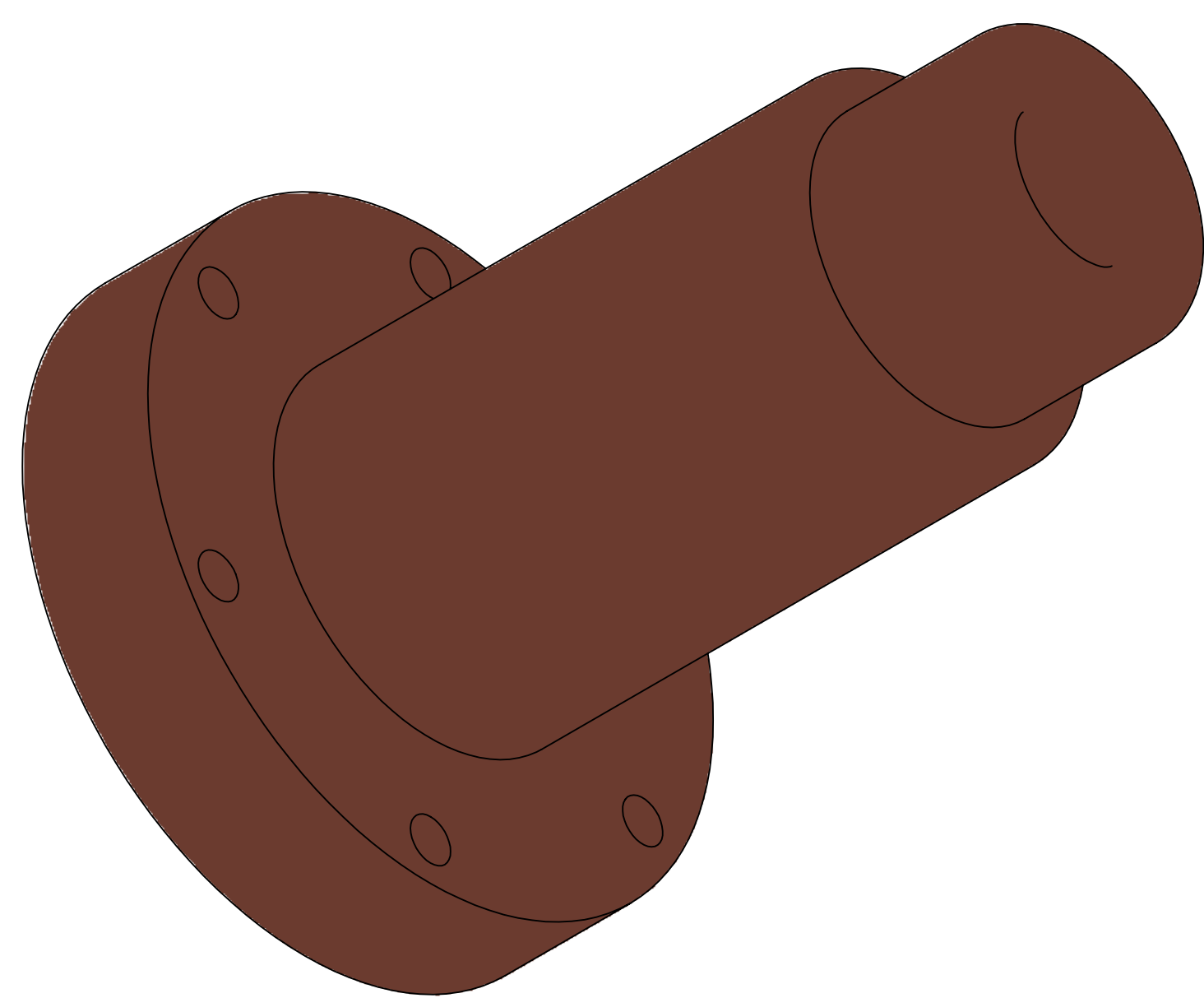
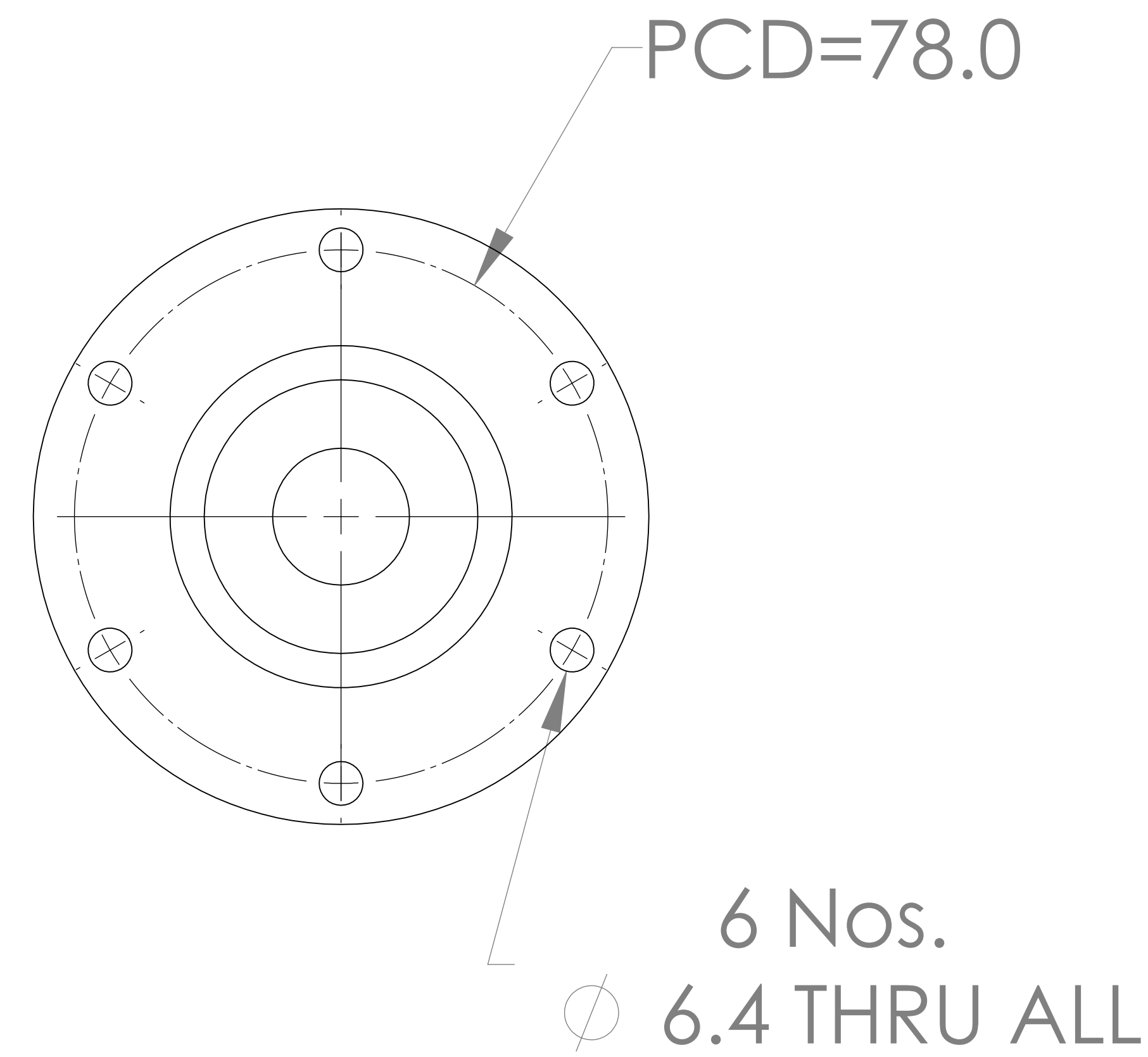
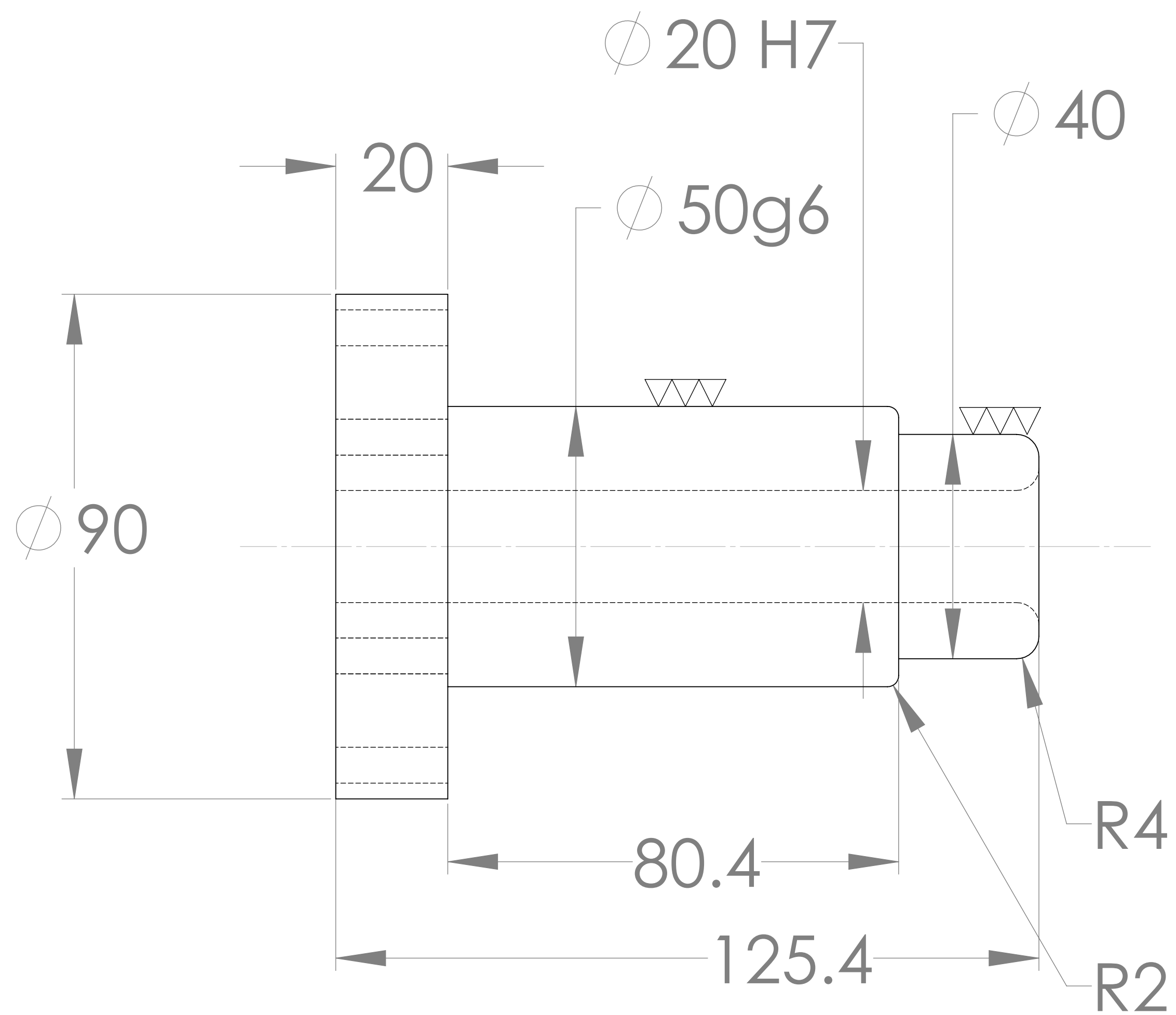

Drawing for Estimation Purpose Only

Gen. TOLERANCES:

ONE PLACE DECIMAL ± 0.1mm
 TWO PLACE DECIMAL ± 0.02mm
 WITHOUT DECIMAL ± 0.5mm
 ANGULAR: ± 0.20 deg.

PROPRIETARY AND CONFIDENTIAL

THE INFORMATION CONTAINED IN THIS DRAWING IS THE SOLE PROPERTY OF IUAC, New Delhi.
 ANY REPRODUCTION, IN PART OR AS A WHOLE, WITHOUT THE WRITTEN PERMISSION OF IUAC, IS PROHIBITED.

ALL DIMENSIONS ARE IN MM

	NAME	SIGNATURE	DATE
DRAWN	DKP		23.3.21
CHKD			
APPVD	RA		
MFG			
G.A			

MATERIAL: ETP Cu
 Qty. : 04 Nos.

Inter University Accelerator Centre
 Formerly : Nuclear Science Centre
 New Delhi - 110067

TITLE:
SIDE DRIFT TUBE

DWG NO : IUAC/HEBT/BUN /09

A1

SCALE:1:1 SHEET 1 OF 1

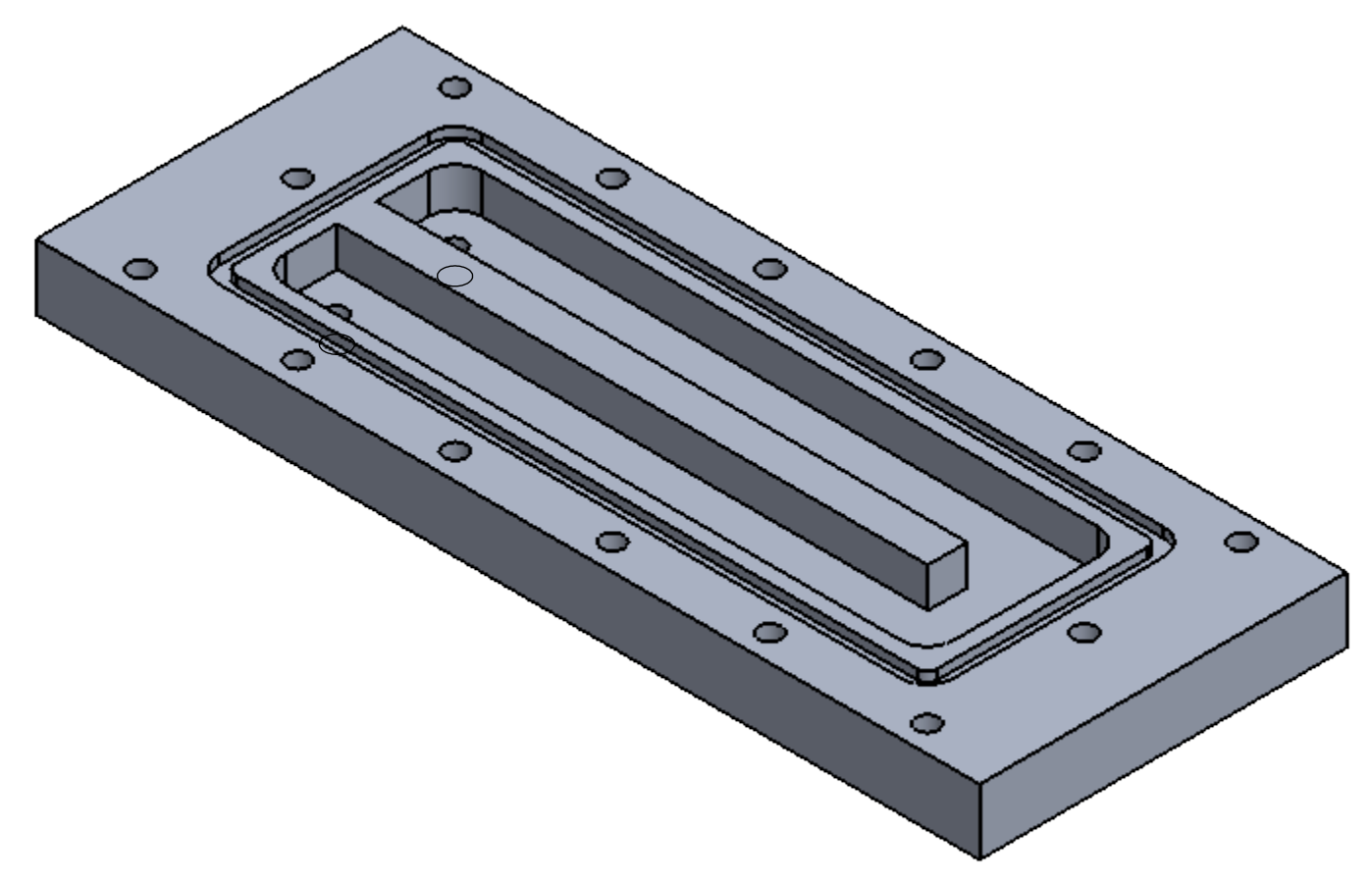
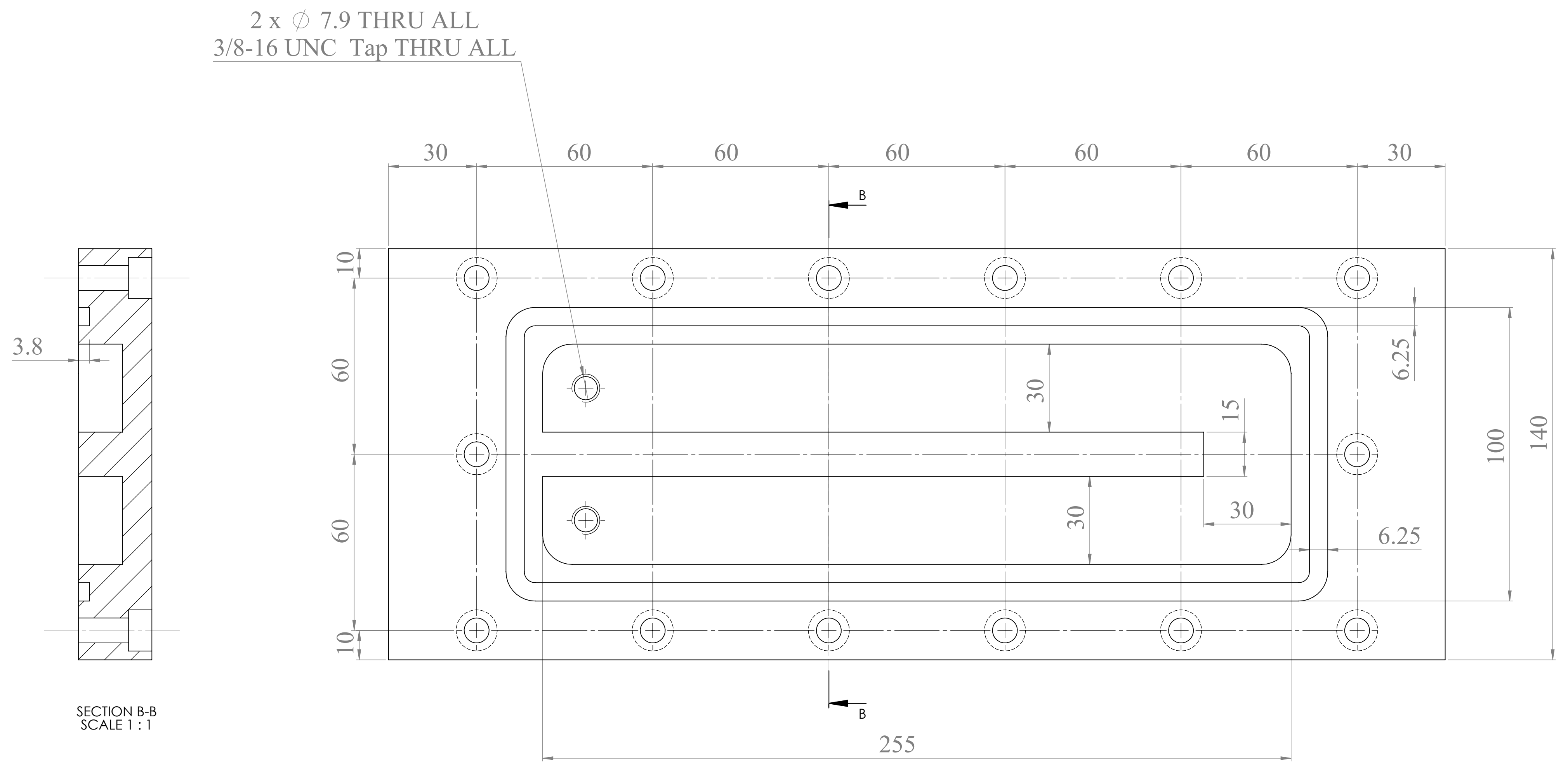

Note :

Vender is required to do Nickle Chrom plating on the Cooling Plates with minimum plating thickness of 10 microns



DRAWINGS FOR ESTIMATION PUPOSE ONLY

Gen. TOLERANCES: ONE PLACE DECIMAL \pm 0.1mm TWO PLACE DECIMAL \pm 0.02mm WITHOUT DECIMAL \pm 0.5mm ANGULAR: \pm 0.20 deg.		PROPRIETARY AND CONFIDENTIAL THE INFORMATION CONTAINED IN THIS DRAWING IS THE SOLE PROPERTY OF IUAC, New Delhi. ANY REPRODUCTION, IN PART OR AS A WHOLE, WITHOUT THE WRITTEN PERMISSION OF IUAC, IS PROHIBITED.		ALL DIMENSIONS ARE IN MM <small>DESUR AND BREAK SHARP EDGES</small>		Inter University Accelerator Centre Formerly : Nuclear Science Centre New Delhi - 110067	
DRAWN: DP CHKD: APPVD: MFG: G.A.		NAME: _____ SIGNATURE: _____ DATE: 23.3.21		MATERIAL: AL Qty. : 20 Nos.		TITLE: Chamber Cooling Plate DWG NO : IUAC/ HEBT/BUN /10	
				SCALE: 1:2		SHEET 1 OF 1	