

## Chapter 3

# RESEARCH SUPPORT FACILITIES

### 3.1 Support laboratories

#### 3.1.1 High vacuum laboratory

Chandra Pal, A. Kothari and P. Barua

High vacuum laboratory is primarily responsible for maintaining vacuum and vacuum systems in beamlines and experimental facilities. There are about 800 instruments (pumps, gauges, valves, diagnostic BPM, Faraday cups, device controllers, etc.) installed and running in different beamlines and facilities. Faulty instruments are replaced with available spares to reduce machine downtime. Indigenously designed and fabricated instruments are repaired in house and others are maintained with available expertise in house and manufacturer's service support. Problems occurring in vacuum system and device (under our group's care) during experiment runs are attended on urgent basis. This lab provides support to different labs and users in vacuum related problems.

##### 3.1.1.1 Installation high energy beam transport beamline of HCI

Chandra Pal, A. Kothari, P. Barua, R. Ahuja, R. Mehta, Kundan Singh and Deepak Munda

Installation and alignment of major HCI HEBT beamline components, [from Achromat I (ACH-I) exit to Achromat IV], was completed in last academic year and all the open sections were connected back and required vacuum was established for starting Pelletron beam to do experiments. Remaining HEBT components were installed and commissioned to conduct out the first beam test in HCI HEBT beamline. A brief description of the work mentioned above is given below:

1. **Fabrication, installation and commissioning of beamline device controllers for HCI HEBT beamline:** Controllers for Faraday cups and beamline valves of HCI HEBT line were installed and commissioned. These controllers can be operated in local as well as in remote mode from control room. It involved the following:
  - (a) Fabrication and assembly of two device controller crates (left panel of Fig. 3.1) for housing device controllers. Each controller crate can house 8 modular device controllers
  - (b) Fabrication and assembly of 2 beamline valve (BLV) and controller and 8 Faraday cup (FC) modular controllers.
  - (c) Fabrication and laying of cables for operation of the installed beam line devices. All the devices were tested ok in remote and local operation.
  - (d) Assembled one spark protection crate (right panel of Fig. 3.1).
  - (e) Prepared signal document (between the device and VME crate) to operate the beam line devices remotely.
  - (f) To operate these device PCLI database was updated in coordination with Remote control group.

### 3. RESEARCH SUPPORT FACILITIES

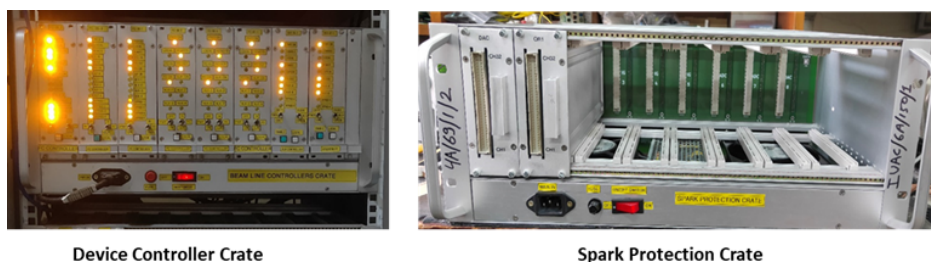

Figure 3.1: Device controller crate and spark protection crate.

2. **Alignment and installation of Spiral Buncher 2:** For installation and alignment of Spiral Buncher 2 [SB-2] in beamhall – 3 the entire beamline section from Achromat 1 to Spiral Buncher had to be vented and relevant section of the beamline was dismantled for placing SB-2. For aligning the SB-2, theodolite was setup near Achromat-2 taking references from existing reference points of the beamline. SB-2 was aligned within  $\pm 1$ mm of beam axis.
3. **Installation and commissioning of vacuum pumps:** New Ion pumps and controllers were installed and commissioned at the various HEBT sections. New turbo pumping system were installed and commissioned for spiral buncher 2 and spiral buncher 3.
4. **Installation and commissioning of indigenous double slit:** An indigenously developed motorized four jaw slit was installed at the entry of Achromat-2. An interface module for operation of the slit controllers through VME control system was designed and fabricated. All the four jaws position calibration was done. The slit is now commissioned and operational from control room

Status: All the beam line devices were successfully made operational from control room and required vacuum was established in the beamline for beam test.

#### 3.1.1.2 Installation and commissioning of indigenously developed motorized four jaw slit

Chandra Pal, A. Kothari, P. Barua, C. P. Safvan and Kundan Singh

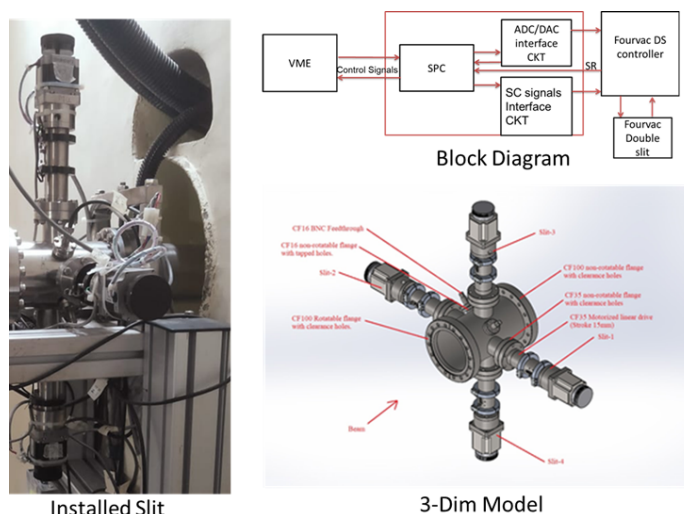

Figure 3.2: Details of four jaw slit.

A motorized four jaw slit (Fig. 3.2) has been successfully developed through a local vendor, customized as per our requirement, at one third of the import cost of the equipment. Each slit jaw can move linearly 0 to 15 mm from centre of the assembly with an accuracy of  $50 \mu\text{m}$ . It is an UHV compatible slit where

each jaw has a power rating of 50 watt and is connected to its corresponding feed-through for reading slit current. It can be operated in local as well as in remote control mode.

Stepper motor is used for precise movement of slit jaws. Jaw controller is having analogue voltage input for each of the four slits. Set positions and current positions are calculated with respect to voltage input of 0-5 DC voltage. Its fabrication and installation in the HCI HEBT section is complete and calibration measurement for accurate positioning of all the four-jaws is done. An interface assembly required for commissioning of the indigenously fabricated four-jaws slit through our VME control system was designed and fabricated inhouse. The four-jaws slit is now operational from control room.

#### 3.1.1.3 Design and development of Faraday cup suppressor unit

There are about 20 Faraday cup units installed at different sections of High Current Injector beamline. To suppress secondary electrons in the FC a suppressor voltage of -380 V is required. Fabrication of 25 numbers of such suppressor units is needed. Communication between FC/Log Amp and FC controller will also be done through this unit. Schematic design and PCB design of the unit is completed using KICAD designing tool. PCB printing is complete and fabrication, assembly and procurement of required parts is in progress.

#### 3.1.1.4 Centralized procurement and testing of new vacuum equipment

A combined order for procurement of vacuum equipment was carried out by vacuum group to meet the various vacuum equipment requirements for all the labs. A total of about 150 equipment were procured and all the items were inspected and tested for its normal operation as per list given below:

1. Turbo Pumps- 12 nos.
2. Turbo Pump controllers – 18 nos.
3. Vacuum Gauges- 58 nos.
4. Gauge Controllers – 26 nos.
5. Ion Pumps – 8 nos.
6. Ion Pump Controllers- 12 nos.
7. Scroll Pumps – 16 nos.

#### 3.1.1.5 Maintenance of vacuum systems and diagnostic devices in beamlines and experimental facilities

1. Maintenance work in Pelletron (with Pelletron group): Venting of high voltage terminal inside Pelletron tank for foil loading and leak check and vacuum restoration after foil loading was done.
2. Replacement of faulty vacuum devices in different beamlines and facilities: Due to continuous and non-stop operation of vacuum devices, few devices get bad and after the fault is established faulty components are replaced from available spares for not stop operations. A list of replaced vacuum and diagnostic devices is given below:
  - (a) BPM 07-2 head assembly stopped working: Area vented and head assembly replaced.
  - (b) AMS beamline Full range gauge faulty electronics and rough vacuum gauge electronics.
  - (c) AMS experimental chamber High vacuum and rough vacuum faulty gauge.
  - (d) AMS beamline faulty Maxi gauge controller (TPG256A).
  - (e) DTL 2 faulty high vacuum gauge replaced.
  - (f) Faulty scroll pump replacement in phase II DB1.
  - (g) Getter Pump cleaning and cartridge replacement – 4 beamlines.
  - (h) Faulty Turbo Pump in Spiral Buncher 1 replaced with spare pump.
  - (i) Failed turbo replaced in HIRA from HIRA spare during beam run.
  - (j) BPM installation at Spiral Buncher for its maintenance work.
  - (k) Faulty MKS gauge in super Buncher replaced.
  - (l) Faulty scroll pump replacement in EQT high voltage platform of HCI.
  - (m) Faulty scroll pump replacement in NII experimental chamber.
  - (n) Faulty scroll pump replacement in Diagnostic box at LINAC exit.
  - (o) Faulty BPM 80 head assembly replacement in LEIBF 105 deg beamline.
3. Commissioning and operation of extended NAND beamline device controllers i.e. FC 09-2, BPM 09-2 and BLV 09-2 from control room:

### 3. RESEARCH SUPPORT FACILITIES

---

New FC controller (FC 09-2) and BLV controller (BLV 09-2), which were fabricated and installed last year, have been interfaced with CAMAC and commissioned in coordination with remote control group. Now these FC, BLV and BPM can be operated from main control room.

#### 3.1.1.6 Testing, repairing and servicing of vacuum equipment

1. Preventive maintenance of Turbo Pumps: Eight next series turbo pumps, operational in different beamlines and experimental stations, requiring oil and bearing change were taken out from the system for the same and serviced by replacing the bearings and oil cartridges at IUAC. Each pump was tested ok after maintenance and installed back in their respective beamlines.
2. Repairing of Scroll Pumps: Two non-functional scroll pumps (model XDS35i) were repaired (Fig. 3.3) onsite and made operational by changing faulty bearings and worn out seals. Orbiting scroll in one pump was found having a crack so it was replaced from available spare.

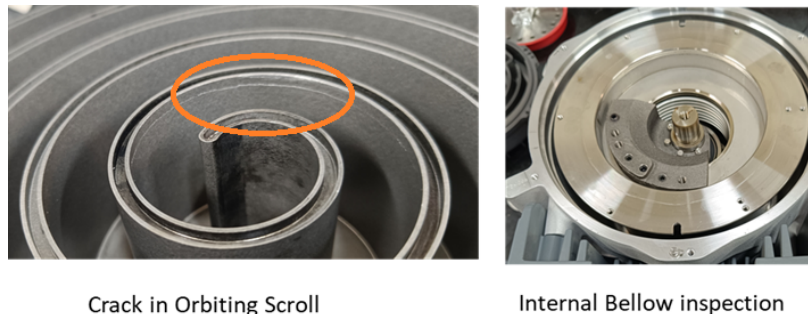

**Figure 3.3:** Scroll Pump maintenance.

3. Repairing of DAC spark protection module (1nos.) of LEIBF high voltage platform spark protection crate.

#### 3.1.1.7 Miscellaneous vacuum maintenance activities

1. There were about 100 calls related to vacuum problems that were attended in different beamlines and experimental facilities. Some common calls are listed below:  
BLV / FC are not closing - opening: caused by compressed air failure, problem in pneumatic drives, CAMAC problems, radiation interlock problems, solenoid valves problems, Reset not done, vacuum pump off / gauge problems, etc. We identify the cause and resolve the issue or convey to other groups if it's in their scope.  
Vacuum Problems: Gauge problem, pump off due to power failure, huge outgassing due to target, leak from joints, pump electronics problem, pump failure, user mistake, vacuum accidents, etc. Problems are identified and resolved, user is advised for leak testing and proper sequence of operation to be followed.  
Leak detective and resolving issues: helping others in resolving critical leak detection problems Venting/ Vacuum Pumping: in beamlines / HCI area upon users request.
2. Cable Re-routing in Phase 1 (Material Science and GDA beamline) : To ease movement under the beamlines the control and communication related to vacuum and diagnostics were re-routed. Many cables were re-fabricated for the same. All connections checked in local and remote, found ok.
3. Linear and Rotary device in NAND Chamber repaired: Power supply in the electronic drive was found defective. A compatible power supply was procured and installed in the system. Its working ok.
4. GP Tube Dismantling / Cleaning / Re-installation Work in LEIBF: Venting of Area between Source and Switching Magnet was done for GP tube cleaning work. Guided and helped the ion source group in dismantling and re-assembly of GP Tubes. Leak Testing support for cleaned GP tubes and vacuum was restored in the beamline after re-assembly of GP tubes.

### 3.1.2 Cryogenics

Manoj Kumar, Suresh Babu, Soumen Kar and Anup Kumar Choudhury

The cryogenic system of LINAC consists of five beam-line cryostats, liquid nitrogen (LN2) network and helium refrigerator, liquid helium (LHe) network, helium gas management system and associated cryo-instrumentation and data acquisition system shown in Fig. 3.4. In this academic year, the LINAC cryogenic system was operated for the beam acceleration through the RF-Superconducting LINAC. The helium refrigerator was also operated for testing a 1.5T superconducting MRI magnet for the IMRI project.

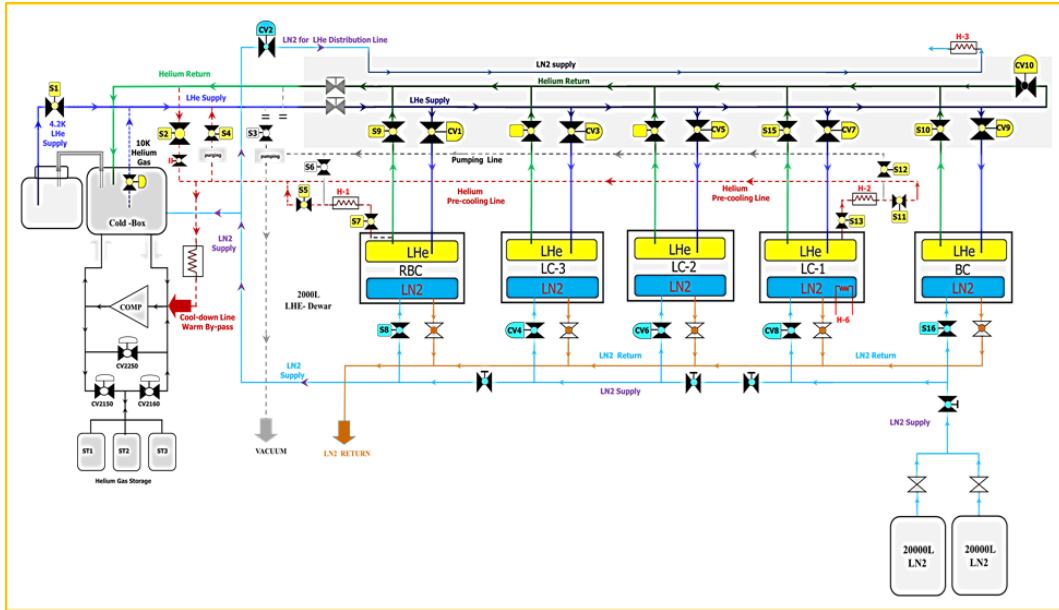

Figure 3.4: Simple schematic of the cryogenic system of the RF-superconducting LINAC.

#### 3.1.2.1 Helium refrigerator

During this academic year, the helium refrigerator (Model- LR280, LINDE Kryotecnik) having a capacity of 750W@4.5 K was operated for ~ 6000 hrs. which is substantially higher than the previous two academic years as shown in Fig. 3.5(a). The plant was operated for the testing of the MRI magnet and the beam acceleration. During the beam acceleration, the helium refrigerator and the associated cryogenic system were operated continuously. There was a minimum beam time loss due to the cryogenic system except for a few intermittent disruptions due to the failure of power or disruption in the water system. The Fig. 3.5(b) shows the number of such interruption and its duration.

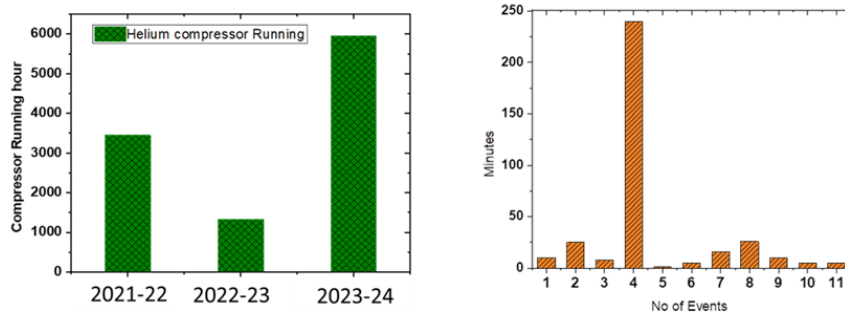
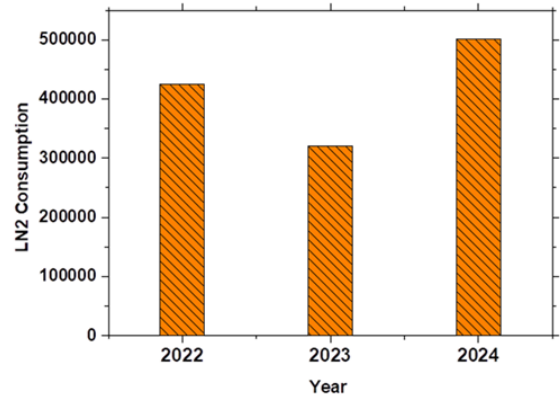

Figure 3.5: (a) Year-wise running hours of the helium compressor, (b) the number and duration of power disruptions during the LINAC campaign.

### 3. RESEARCH SUPPORT FACILITIES

#### 3.1.2.2 Liquid nitrogen network

During this academic year, the total consumption of liquid nitrogen was  $\sim 5,00,000$  liters primarily for the cooling of the thermal radiation shield of the beamline cryomodules during beam acceleration. A substantial amount of liquid nitrogen was also used to cool the germanium detectors of the INGA facility. Fig. 3.6 shows the year-wise consumptions of the liquid nitrogen. A vacuum pumping line was fabricated and installed for maintaining the insulating vacuum of the vacuum-jacketed LN2 network consisting of large sections of straight lines and bends, eight numbers of the U section for the LN2 supply and return line for the cryostats and five LN2 valve boxes. A pumping station was connected at one end of the newly installed pumping line. This common vacuum line has reduced the intermittent pumping of different sections of the LN2 supply/ return lines. The pressure maintained in the LN2 transfer line was  $\sim 5E-3$  bar.



**Figure 3.6:** Year-wise consumption of the liquid nitrogen.

#### 3.1.2.3 Beamline cryostats of the linac

The beamline cryomodules namely the super-buncher cryostat (SBC), three LINAC cryostats (LC1-3) and the rebuncher cryostat (RBC) were cooled to 4.2 K and made ready for the LINAC campaign. Left panel of Fig. 3.7 shows the thermal shield cooling of all the beamline cryomodules. The thermal shields of all three LINAC cryomodules were done by the forced flow of the LN2 and the thermal shields for the SBC and RBC were done by gravity cooling. Once the thermal shield reached the equilibrium temperature, 4K liquid helium (LHe) cooling was done for all the cavities of beamline cryostats. The helium cooling of the cryostats was done sequentially as shown in the right panel of Fig. 3.7.

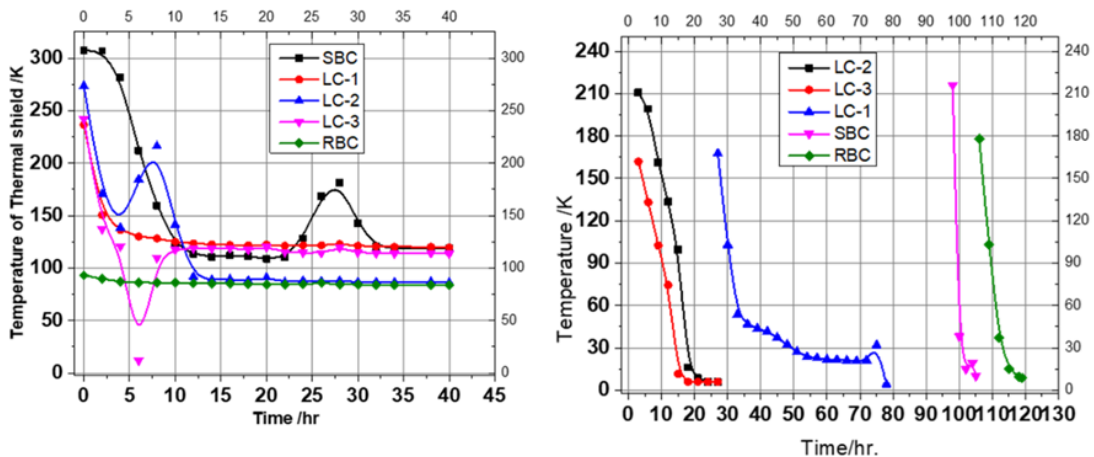

**Figure 3.7:** (a) The equilibrium temperature of the thermal shield of the beamline cryostats of LINAC, (b) the cool-down profile of cryostats by 4K liquid helium.

At the beginning of the shield cooling of the superbuncher cryostat, vacuum deterioration was observed. The vacuum was deteriorated from  $5E-7$  mbar to  $\sim 2E-5$  mbar. To investigate the internal leak of the cryostat, its thermal shield was warmed up to room temperature. The cryostat was vented and opened for investigation as shown in the Fig. 3.8. The leak was finally found in an internal CF port at the bottom of the LN2 vessel which was rectified and the cryostat was revived within a day.

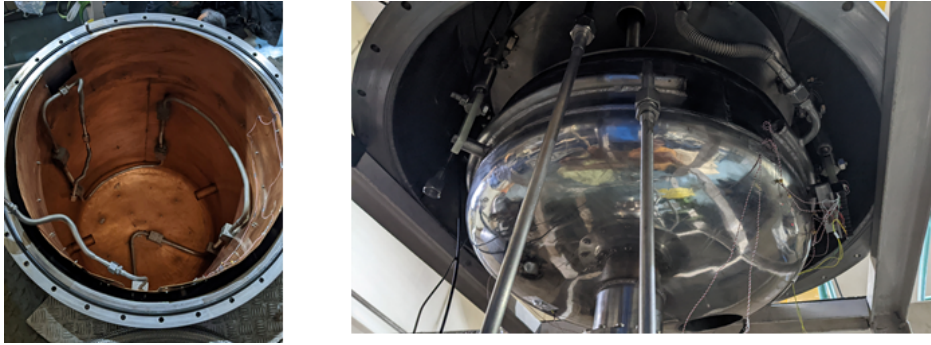

**Figure 3.8:** The internal view of the thermal shield and LN2 vessel of the superbuncher cryostat.

#### 3.1.2.4 1.5 T superconducting MRI magnet system

Ajit Nandawadekar, Bhavana Avasthi, Farukh Khan, Rajesh Nirdoshi, Manoj Kumar, Suresh Babu, S. K. Suman, Joby Antony, S. K. Saini, Rajesh Kumar, R. G. Sharma and Soumen Kar

A multi-institutional project on the development of a whole-body 1.5 T superconducting MRI scanner funded by the Ministry of Electronics and Information Technology (MeitY) is going on at IUAC under the coordination of SAMEER-Mumbai (nodal agency). IUAC is primarily responsible for the development of a 1.5T superconducting magnet system for the MRI scanner. The MRI magnet and the 4K zero-boil-off (ZBO) cryostat were installed in the MRI lab at IUAC after completing the successful manufacturing and integration at the factory site of M/S Inox India. The indigenously developed data acquisition system and the associated control electronics were then installed and integrated with the MRI magnet. All the standard safety measures were put in place before testing the MRI magnet. The magnet was precooled to 100K by LN2 after attaining the desired base vacuum. Fig. 3.9(a, b) shows the precooling of the magnet using LN2 dewar is in progress.



**Figure 3.9:** (a) The precooling of the MRI magnet using LN2 is in progress, (b) the cooling of the MRI magnet using LHe is in progress.

A two-stage GM cryocooler was also started to cool the thermal shield of the MRI cryostat. Fig. 3.10 shows the complete cooling profile of the MRI magnet from 110K to 4.2K. Once the magnet was uniformly cooled to 4.2K, 70% of the liquid was collected inside the cryostat for its testing.

At the beginning, a few preliminary tests of the electrical circuitry of the magnet were performed. The magnet attained a field of 1.5T for the first time without any training quenching. The magnet was ramped to various values in the range of 0.5T- 1.5T to study its various electrical and cryogenic parameters at different fields. The spatial homogeneity and the temporal field stability of the magnet were measured for this unshimmed magnet. The quench protection system and the cryogenic safety system were also successfully tested during a quench of the magnet. Thereby the EM design, bobbin design, magnet winding, dry winding technique, quench protection, electrical insulation, and cryogenic safety system were proven for this magnet. The homogeneity was measured using an NMR field camera. The 5G- safety region was also measured after

### 3. RESEARCH SUPPORT FACILITIES

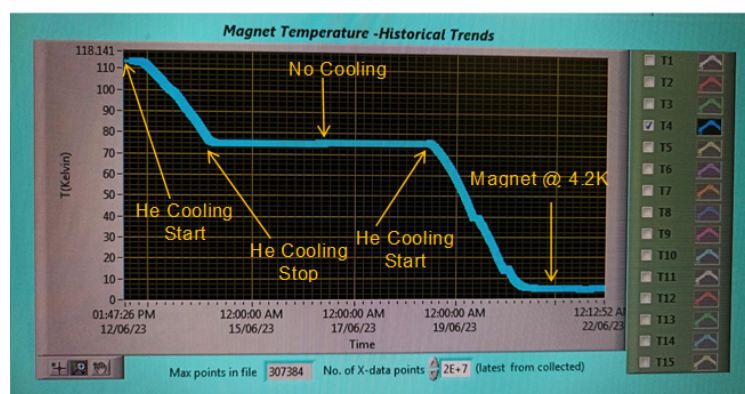

Figure 3.10: The cool-down profile of the MRI magnet system.

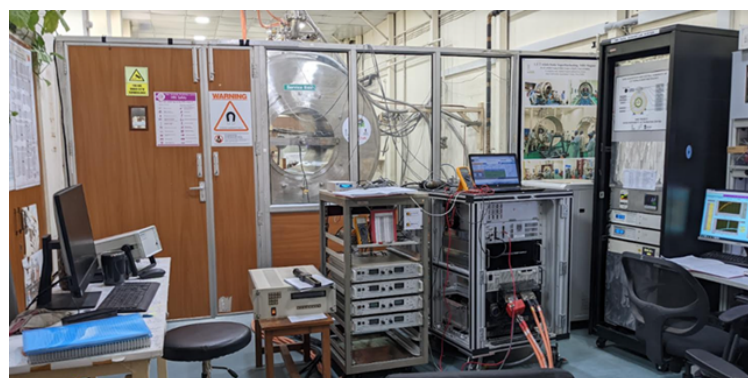

Figure 3.11: The indigenously developed MRI magnet installed in the IUAC IMRI lab.

the field mapping area around the magnet. The safety region is found to be smaller than the USFDA-defined region and hence needs less area for sitting of the magnet at any hospital. The performance of the superconducting EIS coil was also measured which is more than 95% efficient. Although the magnet has achieved most of its design goals, it has also shown a few minor issues which need to be resolved before its use for the clinical scan. Presently, the magnet system is getting ready for the final phase of testing before commissioning for the clinical scan.

#### 3.1.3 Beam transport system

Ashish Chamoli, Prem Kumar Verma, S. K. Suman, Rajesh Kumar and N. Madhavan

The Beam Transport System (BTS) Group is an Accelerator Support Central Group (AcSCG), primarily responsible for the repair and maintenance of beam transport magnets and power supplies of all the accelerators and experimental facilities at IUAC. Besides maintenance and repair activities, the group is actively involved in designing and developing BTS-magnet power supplies for the upcoming HCI and FEL facilities. The yearly activities related to upkeep, maintenance, and development is summarized below

##### 3.1.3.1 Beam transport system

Currently, 153 magnets and 193 magnet power supplies are being used in all of the accelerator and experimental facilities at IUAC. Three major types of BTS magnet power supplies are used in the system. The first type is the model 8000 MPS, which is an older power supply that is installed at Pelletron, LINAC, HIRA,



and HYRA. The second type relatively new is model 9000 MPS, which is installed at HCI and FEL. The third type is the in-house made MPS, which consists of 80 units and is installed in almost all the facilities.

**Maintenance and repair activities:** Yearly Schedule Preventive Maintenance (YSPM) is carried out on all the magnets and power supplies. The maintenance activities are conducted throughout the year, based on the availability of access to different accelerator and experimental facilities.

To enable predictive maintenance actions, the condition of every MPS is pre-analyzed to identify degraded parts. After analyzing the data, specific maintenance plans are created for each unit. This has resulted in nearly no breakdowns in the MPS control and power electronics during beam operations, except for some minor operational issues caused by external interlocks and main power failure.

**Maintenance and repair of model 8000 power supplies:** Although there were no electronic breakdowns in the Model 8000 MPS, there were six major breakdowns caused by water-cooled heat sink leakage, resulting in spilling water inside the power supplies. This resulted in damage to the control and power electronics. When such failures occurred, the power supply required significant refurbishment and repair. For the transportable power supplies, spare units were used as replacements, while the faulty units underwent refurbishment in the lab. However, for the bending magnets MPS, which were not transportable, repairs were done on-site, resulting in longer breakdown times. All the control and power electronics that were damaged due to water spillage were successfully repaired and recovered.

**Maintenance and repair of model 9000 power supplies:** These 30 MPS were installed at High Current Injector (HCI) in 2018 and 40 more were installed in 2023. These are high power density, very compact, and modular units integrated using power and control electronic modules. Over the period, we have understood the failure mode and identified the components that are commonly failing in all the power supplies. The main cause of component failure is thermal stress caused by dust deposition onto the components. We have gained considerable component-level repair skills and repaired almost every module type and there is no repair backlog. Test jigs and PCB extenders were developed to diagnose and make component-level repairs. Spare parts for these power supplies were purchased (imported) this year to support future operations.

**Beam transport system upkeep: Steps taken to improve the sustainability:** Installed Y-strainer filters for every magnet and power supply to filter any sediment present in the cooling water. Also installed flow control valves to set the minimum required flow to reduce the cooling water velocity-related erosion rate.

To reduce the BTS system downtime due to breakdowns, backup power supplies with cable extenders have been installed in places where it is difficult to move heavy power supplies, such as the one on level 03 where there is no easy access. Bulky power supplies are shifted manually up the stairs, which requires 5-6 people.

**BTS installation activities:** This year, we completed and commissioned the High Current Injector Beam transport system (HCI\_BTS) installation; installed 48 magnet power supplies from Achromat-1 to 0° beam line. The installation work consists of rack installation, cable laying/routing for AC power, output DC power, remote control, safety interlocks, grounding, cooling water distribution, and testing at full power to verify the magnetic field and thermal performance.

#### 3.1.3.2 Instrumentation development for IMRI magnet

The BTS group has been actively involved with the Cryogenics group in the development of an MRI magnet at IUAC. The magnet fabrication, assembly and integration into the He-cryostat were completed last year; the preliminary testing of the magnet has been completed this year. The responsibility of the BTS group was to power the magnet, protect it in case of a quench, monitor the current and voltage signals related to the magnet and to provide emergency shutdown option.

**Powering the magnet to the rated current:** A power supply with the necessary control and protection was imported to power the MRI magnet. The power supply failed to place the magnet in persistent mode. Despite several modifications, the issue could not be resolved. Eventually, a BTS-IUAC make 600A power supply was used to power and control the magnet and proved successful in keeping the MRI-magnet under full control in all operational modes.

**Protecting the magnet:** One of the key responsibilities of the BTS group is to protect the magnet by externally dissipating the stored energy in case of a quench while powering the magnet. The BTS group designed and delivered an Energy Absorber Unit (EAU). The EAU successfully dissipates the stored energy during the ramping down mode and magnet quench. The magnet was able to sustain a full quench,

### 3. RESEARCH SUPPORT FACILITIES

dissipating 3.5 MJ of stored energy. The passive & active quench protection system evenly distributed the stored energy, preventing the generation of high temperature, high voltage, asymmetrical Lorenz forces.

**Magnet auxiliary system controllers:** The BTS group successfully designed, developed and installed a cryostat pressure controller, an external interference screening (EIS) coil controller and an emergency run-down controller. These controllers are customized units, specifically developed as per the magnet specifications.

**Monitoring of magnet voltage and current parameters:** An eight-channel signal isolation amplifier unit has been designed and installed to isolate the signals directly tapped from the magnet coils. The unit avoids any unintended short to ground through the Data Acquisition System (DAQ) and in turn avoids the quench or destruction of the magnet.

It is also desirable to accurately determine and monitor each coil voltage profile continuously during all operational scenarios like powering, quench and persistent mode to monitor the superconducting state of each coil. The high voltage generation ( $\pm 2$  kV/coil) in the event of quench, forces stringent requirements of isolation on measurement instrumentation. Extracting the voltage corresponding to resistive transition (which is in the range of mV), in the presence of the high “common mode” voltage generated by the coil stack, is much more difficult than might be supposed. Hence, for accurate measurement, a lot of attention is to be paid to grounding, shielding and isolation up to the DAQ. All magnet-related signals were successfully recorded during all magnet ramping modes and quench.

#### 3.1.3.3 Instrument repair support

BTS group has been providing extensive instrument repair services in the field of power supplies and power electronics to other labs at IUAC as well as to other institutes. This year, the following instruments were repaired by BTS group members; Dipole magnet power supply-Punjab University; Magnetic barrier separator system-IUAC Geochronology; Mossbauer drive unit-IIT Kanpur; PPMS Power Supply-IIT Delhi.

#### 3.1.4 Detector laboratory

Mohit Kumar and Akhil Jhingan

Detector Laboratory at IUAC provides experimental support to various users in setting up charged particle detectors and readout electronics. New detectors and electronics have been designed and developed, and are used in various nuclear physics experiments.

##### 3.1.4.1 Electronics for LaBr scintillator detectors in INGA

A. Jhingan, M. Kumar, Yashraj, I. Bala and R. P. Singh

Custom-designed preamplifier units were designed and fabricated to process signals from LaBr<sub>3</sub>(Ce) scintillators coupled to photo-multiplier tube (PMT). Two versions were developed: charge sensitive preamplifier (CSPA) for energy measurements and a fast timing amplifier (FTA) for timing measurements. The CSPA, with a sensitivity of 4.5 mV/pC (Si equi.), processes the signal from dynode output of the PMT whereas the FTA (gain  $\sim 5$ ) is used to process the anode signal. The use of preamplifier units facilitates signal transmission through long cables from INGA beam-line to the data room. At the same time it allows operation of detectors at lower PMT bias, which otherwise can introduce non-linearities at higher bias. Use of these preamplifier units also improves the signal-to-noise ratio thus enhancing the resolution of the system. Further processing of CSPA signals is performed using the earlier developed system for CsI detectors. The CSPA output is fed to a NIM differential driver unit which drives the differential energy

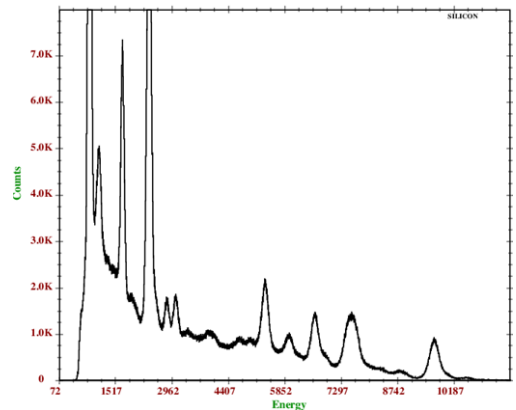

**Figure 3.12:** <sup>152</sup>Eu  $\gamma$ -ray spectrum with LaBr<sub>3</sub> detector.

signal to the 16 channel Mesytec (MSCF series) spectroscopy amplifier. The FTA output is fed to high resolution constant fraction discriminators (CFD) such as Ortec 935 or Phillips 715. Five sets of preamplifier units were developed for five LaBr<sub>3</sub> detectors used in INGA facility. An energy resolution of  $\sim 2\%$  (1.33 MeV  $\gamma$ -rays) and a time resolution of  $\sim 350$  ps (FWHM) with <sup>60</sup>Co source was observed. The modular CsI electronics developed earlier can be easily adapted to process signals from 32 LaBr<sub>3</sub> detectors. Fig. 3.12 shows the spectrum from  $1.5'' \times 1.5''$  LaBr<sub>3</sub>(Ce) with <sup>152</sup>Eu source at a bias of 1000 V.

### 3.1.4.2 Testing of CsI detector coupled to APD

A. Jhingan<sup>1</sup> and R. Palit<sup>2</sup>

<sup>1</sup>Inter-University Accelerator Centre, Aruna Asaf Ali Marg, New Delhi 110067, India

<sup>2</sup>Department of Nuclear and Atomic Physics, Tata Institute of Fundamental Research, Mumbai 400005, India

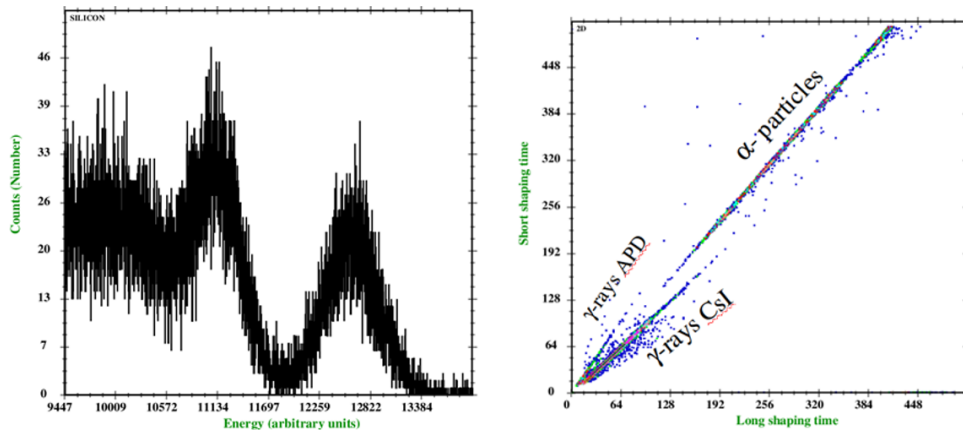

**Figure 3.13:** (Left) Spectrum of <sup>60</sup>Co  $\gamma$ -rays from CsI-APD combination and (right) PSD plot using BD technique showing clean separation between  $\gamma$ -rays and  $\alpha$ -particles.

The performance of a CsI(Tl) detector coupled to an Avalanche Photo-Diode or APD was evaluated using radioactive sources. The CsI(Tl) detector is 3 mm thick and was coupled to a 10 x 10 mm<sup>2</sup> APD (Hamamatsu S8664-1010) via a 7 mm thick plexi-glass light guide. Unlike photo-diode which operates with bias voltage of 30 – 40 V, the APD requires a bias voltage ranging from 250 – 400 V, but provides higher inherent gains, while maintaining linearity and resolution. The APD is read by conventional charge sensitive preamplifier (CSPA) with a gain of 2 V/pC (Si equi.), already in use with CsI-photo-diode based CPDA. The detector bias network of the CSPA was modified with high voltage resistor and capacitor network. The detector system was tested with radioactive sources namely <sup>241</sup>Am, <sup>137</sup>Cs and <sup>60</sup>Co. Comparative studies were made with CsI-photo-diode detector of identical size along with a NaI detector coupled to PMT. The signal strengths were found to be about 10 – 30 times higher as compared to normal photo-diode signal. The signal strength is a function of applied reverse bias in APD. As an example, a gain of 300 mV/MeV is observed for  $\gamma$ -rays whereas it is constant 10 mV/MeV with photo-diode. Higher inherent gain of APD is useful in the detection of low energy  $\gamma$ -rays such as 59 keV from <sup>241</sup>Am which otherwise is not possible with a normal photo-diode. With given CSPA gain, signal strengths are almost identical with NaI-PMT combination. Resolutions achieved are identical for all three. Left panel of Fig. 3.13 shows the spectrum with <sup>60</sup>Co source. Energy resolution is  $\sim 5\%$  for 1.33 MeV  $\gamma$ -ray. Another interesting observation with APD is identical energy resolution with both short and long shaping times. In contrast, photo-diode resolution is severely deteriorated at shorter shaping times (0.5 – 1  $\mu$ s). CsI-APD combination was also tested for its particle identification ability by using ballistic deficit (BD) technique with short (0.5  $\mu$ s) and long shaping time (3  $\mu$ s). As shown in the right panel of Fig. 3.13, a clean separation is observed between  $\alpha$ -particles and  $\gamma$ -rays of CsI and APD. CsI-APD combination will be very useful for physics cases which require detection of these light particles with energies ranging from few hundred keV onwards. More tests will be carried out in future.

### 3. RESEARCH SUPPORT FACILITIES

---

#### 3.1.4.3 MCP-based TOF system for GPSC

Sunil Devi<sup>1</sup>, R. Yattoo<sup>1</sup>, M. Kumar<sup>2</sup>, C. P. Safvan<sup>2</sup> and A. Jhingan<sup>2</sup>

<sup>1</sup>Inter-University Accelerator Centre, Aruna Asaf Ali Marg, New Delhi 110067, India

<sup>2</sup>School of Physics and Materials Science, Thapar Institute of Engineering and Technology, Patiala 147004, India

Mechanical design of the MCP detector assembly was carried out. The fabricated frames (designed on CAD software) were received from the vendor. The assembly includes frames for preparing electrostatic mirror, mounting frames for MCP in Chevron configuration, Anode plate, and integrated card having a voltage divider network and fast timing amplifiers (FTA) for signal processing. For extracting position information, multi-wire frame with differential delay line technique will be utilized. Two versions of FTA have been designed for the same. The first one has an active differential input whereas the second one has a transformer coupling. It is proposed to evaluate both designs. Fig. 3.14 shows the CAD generated schematic of the electrostatic mirror. This project is funded by DST-SERB via sanction order no. CRG/2020/005552.

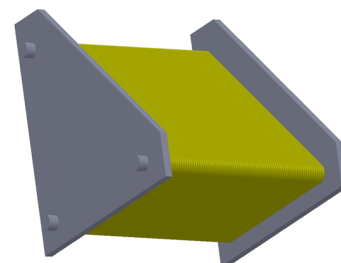

**Figure 3.14:** CAD schematic of the electrostatic mirror.

#### 3.1.4.4 Detector system for investigating MNT reactions in GPSC / NAND

M. Kumar, A. Jhingan, N. Saneesh, K. S. Golda and P. Sugathan

Developmental activities have been initiated to have a modular particle identification system for performing multi-nucleon transfer (MNT) reactions in GPSC/NAND. It is proposed to have both time of flight (TOF) and differential energy loss parameters for particle identification system along with angular distribution information. The new detector system will have a larger solid angle for longer flight paths, and will provide simultaneous measurement at more angles with a possibility of measurements at extreme backward angles. The TOF system will have a combination of MCP and MWPC detector, and the differential energy loss system will have gas-silicon hybrid telescopes. Earlier, HYTAR telescopes were used which had a smaller solid angle ( $\sim 0.2$  msr) at larger flight paths. The new system will have a larger area axial field IC and silicon detector, and will have a solid angle coverage of  $\sim 1$  msr for each detector. The flight paths will be 50 – 55 cm in case of GPSC, and possibly 35 – 40 cm for NAND.

#### 3.1.5 Target development laboratory

Abhilash S. R., D. K. Prabhakar, Ambuj Mishra and Debdulal Kabiraj

##### 3.1.5.1 Target development for accelerator users

The primary responsibilities of Target Development Laboratory (TDL) are the operation, up-keeping, and maintenance of instruments in the lab for developing, preserving, and delivering the nuclear targets and thin films for particle accelerator users. TDL is successful in delivering all the requested targets for accelerator experiments and several research scholars have been trained in thin film deposition techniques in this year. Most of the instruments in target lab are well-utilized in this year except the UHV Evaporator with multi-pocket electron gun (e-gun). Target developments in IUAC were also reported in peer-reviewed journals [1-6] and national symposiums in this year.

##### 3.1.5.2 Fabrication, inspection and loading of stripper foils

Target Lab usually fabricates the stripper foils twice a year according to the Pelletron maintenance schedule. Approximately 200 carbon foils of  $4 \mu\text{g}/\text{cm}^2$  for the terminal section and 200 foils of  $8 \mu\text{g}/\text{cm}^2$  thickness for the dead section. Target development laboratory develops carbon stripper foils by e-beam bombardment techniques. High-purity graphite is evaporated and condensed over the glass substrate coated with a releasing agent. To ensure the maximum uniformity in the thickness of the films, the glass substrates are rotated during

the evaporation. A dedicated turbo pump-based e-beam facility is used for the stripper foil fabrication. In addition to the IUAC stripper, imported Pulsed Laser Ablated (PLA) foils are also used in Pelletron. PLA foils exhibit superior life as stripper foils. The purchased PLA films are delivered as coated on substrates with a thin copper protective layer in between the releasing agent and the carbon layer. After separating the films from glass substrates, the films are transferred to a nitric acid solution to dissolve the copper backing. Finally, the carbon films are mounted on the stripper foil holder.

### 3.1.5.3 Maintenance and up-gradation activities

In addition to the regular operation, the major maintenance activities are cleaning of the chamber, gauge cleaning, periodic maintenance of electrical systems, periodic maintenance of QCM, leak testing, cooling water supply, and performance testing. The Breakdown maintenance of the Rolling Machine was one of the major maintenance activities in TDL during this year. After the disassembly of the machine by TDL members, it was identified that the breakdown was due to the failure of the gears. A cost-effective yet robust custom gear train which was manufactured indigenously by a vendor was successfully replaced. The machine is back in operation after several tests with loads. Maintenance and recalibration of the Profilometer was done by M/s Bruker's authorized representatives under supervision and support TDL personnel.

### 3.1.5.4 Target library for users

The Target Library, TDL initiated in the year of 2019 for systematic storing of the nuclear targets for future use and for avoiding repeated fabrication of targets having the same specifications. Apart from saving money and manpower, this facility also helps users to plan experiment depending on the availability of target. The Digital Inventory of the Target Library is maintained and updated periodically. A list of targets and their specifications are available in the digital form. More than 1200 targets are already part of the library and new targets are getting added after the completion of the experiments for those these targets were fabricated. The Target Library has issued more than 50 targets in 2023 for various experiments. The air-sensitive targets for longer duration is always a challenging job. The dedicated high vacuum storage facility for the target is not yet materialized. At present, the targets are stored in vacuum desiccators which are filled with argon gas. A stock of 200 carbon stripper foils is maintained in the library to meet any unexpected requirement.

### 3.1.5.5 A few important target development

Target development by physical vapor deposition technique using e-beam bombardment involves excessive heating of the substrate surface which tends to degrade the parting agent. To reduce this the source-to-substrate distance is increased, however, more distance between the source and substrate results in more material consumption which has to be minimized for optimal consumption of expensive isotopically enriched materials. To reduce the substrate heating, a substrate cooling set-up has been developed with the help of the IUAC workshop. The setup has been successfully used for the development of targets of expensive isotopes like  $^{142}\text{Nd}$ ,  $^{150}\text{Nd}$ ,  $^{193}\text{Ir}$ ,  $^{194}\text{Pt}$ ,  $^{198}\text{Pt}$ .

## 3.1.6 RF amplifiers and low-level RF group

Ashish Sharma, Parmanand Singh, Yaduvansh Mathur, V. V. V. Satyanarayana, Arti Gupta, S. Venkataramanan and Abhijit Sarkar

### 3.1.6.1 RF power amplifiers of Pelletron, SC-linac, HCI and DLS

The RF group is responsible for managing a variety of high power RF amplifiers and microwave power sources. The group has been actively involved operation, repair, development and undertaking of periodic preventive maintenance of power sources and amplifiers under care. These are installed with Pelletron and High Current Injector (HCI), Super Conducting Linac (SC-Linac), Delhi Light Source (FEL-DLS) and LEIB accelerator facilities. These power amplifiers and microwave power sources have wide range in both frequency of operation and operating power level ranging between 4 MHz to 17.9GHz and 100's Watts to 10's of megaWatts. Throughout this year, all the power amplifiers and microwave power sources were in continuous operation at different power levels as per requirement. The power amplifiers installed are of both

### 3. RESEARCH SUPPORT FACILITIES

---

water-cooled and air-cooled types. The dust filters of these equipment are routinely cleaned and replaced. The cooling water quality to HCI, DLS installed equipment is also monitored and replenished whenever necessary. Regular logging of utility and equipment parameters in a day are part of the routine. Major preventive maintenance operation of all power amplifiers under care have been completed as per schedule and documented. Purchase of required spare components, sub-units, spare power supplies, control cards and various consumables have been initiated and completed for maintaining a stock of spare components in order to ensure efficient operation of installed RF power amplifiers and microwave power sources. Apart from the above routine activities, the group members are also engaged in various academic activities of newly recruited apprenticeship trainees, scientists, engineers and junior engineers during this year.

**Microwave power generators:** In order to provide different particle beams for HCI, the 1.7kW CW Klystron based Power Generator for ECR ion source (PKDELIS) at IUAC has worked successfully and continuously up to 1000 Watts. This forced air-cooled power generator is regularly cleared of dust and debris. In order to decrease transmission line junction loss and maintain a consistent transmission route between the microwave power generator and plasma chamber at 17.9GHz, a variety of WR-62 type wave guide components were purchased and installed. During this time, a long-standing issue with the control and display (C&D) unit of this power generator was fixed and a replacement relay was installed.

One of the windings of the three-phase, 415 V, 10 kVA Auto Variac (Servo transformer) of the Klystron anode high voltage power supply was found to have burned during a significant failure. This probably caused imbalance in the load and generating high harmonic currents which probably damaged MOVs in its Anode supply voltage section. The auto transformer (Variac) was rewound and repaired through a local vendor. The interlock interlock circuit was modified and tested the Klystron power generator on dummy load before successfully restored it back to the ECR ion source system.

**120kW, 48.5 MHz RFQ power amplifier:** This year, the Radio Frequency Quadrupole (RFQ), which is powered by a vacuum tube amplifier based on tetrode, was regularly powered up to 25kW. In accordance with the amplifier supplier's instructions, we have worked this year to commission a specialized low conductivity water (LCW) plant to feed the tube amplifiers for liquid cooling in collaboration with the water supply group. This year, in order to remotely monitor the different supply and tube characteristics of the power amplifiers, we included "Grafana" into our system.

**20 kW solid state power amplifiers:** During this year the 97 MHz, 20 kW CW solid state power amplifier powering DTL-2, DTL-3 cavities respectively have performed reliably throughout the year. A faulty water flow sensor that has been replaced in one of the power amplifiers. These power amplifiers have critical operational parameters that may be read and controlled remotely via the RS-232 control. A blown LDMOS transistor was replaced in order to fix a malfunctioning amplifier pallet and replace a malfunctioning SMPS (3kW) unit.

**28 kW solid state power amplifiers:** The DTL-4 and DTL-5 cavities were powered by 28 kW CW solid state power amplifiers operating at 97 MHz and on a regular basis. The Driver power amplifier was repaired for faulty CATV pre-driver and reason for inconsistent in performance was identified and rectified. One of these power amplifiers was used to power the DTL-6 cavity through the RF power Circulator, whenever the corresponding DTL-6 Triode power amplifier was under repair during this year.

**30 kW vacuum tube power amplifier:** DTL #6 was powered by a 30 kW CW vacuum triode power amplifier operating at 97 MHz that experienced a cooling water leak during regular operation. A small hole in the return line water coupling, which was caused by an OEM-supplied Polycarbonate union joining the cooling water hose and RF tube, was leaking water. After consulting with the OEM, the union was replaced with in-house manufactured glass reinforced teflon couplings, however they also failed. Another set of unions of originally installed models were sourced and installed, but again failed with similar symptoms during normal operation. Later, we replaced them with brass unions that were locally produced, and we regularly tested them to full power using a dummy RF load. A spare vacuum triode was used to restore the power amplifier.

The high voltage filter capacitor in the anode high voltage supply shorted in another breakdown. Since we didn't have a replacement in stock, a high voltage oil capacitor made locally was installed to address the issue. This year, in order to remotely monitor the different supply and tube characteristics of the power amplifiers, we added "Grafana" to our monitoring system.

**Hi-potting of vacuum tubes:** The spare power vacuum tubes of 120kW, 30kW and 6kW power amplifiers are being put through hi-potting test periodically with homemade Hi-potting setup. To maintain the health of the power vacuum tubes and prevent vacuum degradation during storage, hi-potting conditioning was carried out on a regular basis.

**400 W RF power amplifiers:** The SC-Linac cavities are driven by about 35 custom-built 400 watt solid state radio frequency power amplifiers. Due to the Pelletron + SC\_Linac campaign, which lasted for about five months this academic year, the group members were often addressing issues with the malfunctioning power amplifiers. Due to water leakage caused by worn brass nozzles in water couplings and surface contamination of printed circuit boards, aged power amplifiers are exhibiting poor reliability and performance. In collaboration with the workshop group, 14 SC-Linac 350W CW, 97MHz solid state power amplifiers that were malfunctioning were fixed for water joints and VHF core-related problems this year, and they were then put back into service.

We have already begun designing a new solid state RF power amplifier using LDMOS RF FETS to replace most of the current VHF power amplifiers. The new power amplifier, which will be remotely controlled and monitored via RS-232 and “Pelcon” compatible interfaces, will include all additional circuitry included in the current power amplifier design after consulting with the SC\_Linac operation group.

### 3.1.6.2 Development activities

**Development of 3 kW, 48.5 MHz solid state RF power amplifier for spiral buncher:** Due to their improved specifications, reliability, and widespread availability, we have continued to work on the development of SS power amplifiers for Spiral Buncher cavities of HCI using 6th generation LDMOS devices for RF power core. A 4-Way lumped Wilkinson RF Splitter and Combiner are installed in the power amplifier along with Dual Directional Coupler. The four RF power core units are driven by a driver amplifier. The aggregate power of these four devices’ output results in 3 kW of RF power at the output. Implemented is a generic control card with all required interlocks, readbacks, and controls. One such created amplifier is integrated with the Spiral and tested up to 1.7 kW using an RF dummy load. Assembly of two more such amplifiers are under progress.

**Development of 100 W broadband solid state RF power amplifier for chopper / MHB:** Broadband solid state RF power amplifiers are being developed with state of the art RF components for Chopper and MHB of Pelletron and HCI which are capable of delivering up to 100 W (CW) in the frequency range of 10 MHz – 50 MHz. Several precautions, including VSWR, over-temperature, input overdrive, and external interlock, are included into these amplifiers. The modular design is facilitates the maintenance and enhancement easier. The power monitoring is possible with custom built dual directional coupler and front panel power meters. The amplifier is assembled in a 3U height 19” rack mountable standard chassis. These power amplifier core units are mounted on water cooled copper heat spreader. At present status various power core units assembled and awaiting complete integration of these units in a 3U, 19” aluminum chassis.



**Figure 3.15:** Pelletron beam pulsing system electronics with multi-level fault detection system.

### 3.1.6.3 Low-level radio frequency electronics

As a division of Radio Frequency (RF group), the Low-Level RF (LLRF) group serves as an Accelerator Support Central Group (AcSCG) and is responsible for the creation, upkeep, and operation of various LLRF systems for all IUAC accelerators. Along with control electronics for the Multi-Harmonic Buncher (MHB), Chopper, Travelling Wave Deflector (TWD), LLRF controllers for Linac, High Current Injector (HCI), and Free Electron Laser (FEL), this also contains the Beam Pulsing System of Pelletron-Linac (BPS). A synopsis of the group’s activity from the previous academic year is provided in the subsections that follow.

### 3. RESEARCH SUPPORT FACILITIES

**Table 3.1:** Pulsed beam runs during 2023-24.

Pulsing run	Energy (MeV)	TWD	Facility	No. of shifts
<sup>28</sup> Si, 9+	80-130	2 $\mu$ s	HIRA	15
<sup>32</sup> S, 11+	116 - 156	OFF	NAND	21
<sup>30</sup> Si, 10+	124 - 137	OFF	GPSC-II	15
<sup>28</sup> Si, 9+	120	OFF	GPSC-II	24
<sup>16</sup> O, 4+	46 - 81	2 $\mu$ s	HIRA	21
<sup>28</sup> Si, 9+	106 - 127	2 $\mu$ s	HIRA	18
<sup>48</sup> Ti, 6+, 14+	145	OFF	LINAC TUNING	12
<sup>48</sup> Ti, 6+, 14+	285	OFF	NAND	24
<sup>48</sup> Ti, 6+, 14+	188 - 214	OFF	HYRA	24
<sup>48</sup> Ti, 6+, 14+	236 - 259.4	OFF	HYRA	24
<sup>48</sup> Ti, 6+, 14+	125 - 156	OFF	HYRA	15
<sup>30</sup> Si, 9+	125	2 $\mu$ s	HYRA	21
<sup>30</sup> Si, 9+	154	OFF	NAND	24
<sup>30</sup> Si, 9+	170 - 200	2 $\mu$ s	HYRA	12
<sup>32</sup> S, 9+	164 - 200	2 $\mu$ s	HYRA	12
<sup>28</sup> Si, 9+	160	2 $\mu$ s	HIRA	18
Si, 9+	180	OFF	NAND	15
<sup>28</sup> Si, 9+	160	OFF	INGA	15
<sup>28</sup> Si, 9+	145	OFF	INGA	15
<sup>31</sup> P, 9+	115	OFF	NAND	24
<sup>16</sup> O, 6+	131	OFF	NAND	24
<sup>12</sup> C, 6+	125	OFF	NAND	21

**Operation of beam pulsing system for Pelletron-linac:** The beam pulsing system (Fig. 3.15) saw heavy use this year for a number of pulsed beam run for nuclear physics experiments, particularly during the longest SC\_Linac run, which lasted nearly six months. Table 3.1 summarizes the Beam Pulsing system's operation and displays the many types of beams grouped together with their energy, shift counts, and user facilities. The pulsating system's performance for this year is displayed in a pie chart, and the system's uptime is reported at above 99%. Beam runs are still ongoing, and there were 22 pulsed beam experiments, including the one for SC\_Linac tuning at the start of this SC\_Linac run. Seven pulsed beam experiments were conducted with the Travelling Wave Deflector (TWD). Seven pulsed beam experiments were conducted using the Travelling Wave Deflector (TWD) and the operating performance was extremely good. This year, the pulsing system has been used for 414 shifts, 138 days, and 3312 hours of operation. Apart from their designated tasks, every member of the group is actively involved in the Beam Pulsing system operations 24/7.

Numerous diagnostic devices are developed to ensure the system operates efficiently. One such device is the beam phase meter, which shows the beam phase locking system's default phase setting. If phase out of lock occurs, it is easy to fix by just adjusting the MHB phase to the default phase value, which won't interfere with beam operation or user data collecting. In the event of a malfunction, the TWD HVPS interlock protects the integrity of all deflecting plate electronics and locks the HVPS to prevent more damage. Additionally, after verifying the interlock state, it permits manual ramping of the high voltage. In the event of a significant malfunction, replacement modules are maintained in stock. There are ongoing indigenous developments of the whole Beam pulsing electronics system. During TWD runs, one such diagnostic was set up to optimize the pulsed beam. In the past, user feedback was used to optimize TWD for any observed satellite peaks. At the moment, a Time of Flight (ToF) system with a Time to Amplitude Converter (TAC) is set up in the control room. Before sending the beam to the user, beam and TWD signals are utilized to verify the satellite peaks and optimize the TWD.

**Preventive and breakdown maintenance of RF systems** As planned, the preventative maintenance of the systems under care was completed in April 2023. Along with routine preventative maintenance, the group members were shown how to tune the MHB tank circuit coils in the Pelletron Beam Pulsing System, and now every group member is comfortable in tweaking and maintaining the system. There was only one malfunction with the TWD electronics during this year, and it was quickly fixed in-situ without causing any loss of user beam. During the recent SC\_Linac campaign, there were not many in-situ corrective



maintenance of the SC-Linac LLRF controllers.

For the Pelletron Beam Pulsing system, the electronic units are located in the main control room as well as on the fifth floor of the accelerator tower A a multi-level fault detection system has been installed to locate the defect and assists in fixing the defects within short time to avoid beam time loss. This includes the TWD deflecting plate electronics status display with interlock, manual ramping of high voltage power supply for TWD with interlock, TWD optimizer to minimize the beam time loss, particularly during HIRA/HYRA experiments, and the beam phase display on control console to detect and locking of MHB to the right phase using Chopper - MHB phase detector.

**3.1.6.4 Support to various RF systems**

Being an Accelerator Support Central Group (AcSCG), this group is involved in ongoing activities in various facilities at IUAC. One of them is the HCI to Linac beam injection test during December 2023. The entire group contributed to ensure all RF systems (comprises of LLRF controls and RF amplifiers) are in working order. During this facility run, the clock for HCI LLRF was derived from the Master clock driving the SC\_Linac control from control room, so that the HCI beam could be injected into the SC\_Linac. LLRF controls for Spiral bunchers #2 and #3, RF Multiplexer, etc. were also incorporated. All the RF systems were operated remotely during beam acceleration. The required electronics were development by this group and required cables were made, routed and tested before the actual beam test in coordination with other groups.

**3.1.6.5 Preventive maintenance for the SC-linac LLRF electronics**

A total of around 10 Resonator Controllers and 3 Piezo Tuner Controllers have been repaired and readied for the 6-month long LINAC experimental run in 2023-24. As part of corrective maintenance activities during the experimental run, all the faulty electronic modules were serviced, repaired, and tested in a room-temperature test setup as and when they are received in-situ. Repair logs have been updated properly in the logbook as per the standard repair format.

**3.1.6.6 Development of electronics for various LLRF systems**

The development of electronics depending upon the requirements and the process of upgradation of the existing systems is a continuous process. Few developments have taken place this year and they are mentioned here.

**Development of Pelletron beam phase locking electronics:** Beam phase locking electronics to supplement the existing electronics have been developed and tested in the laboratory as shown in the Figs. 3.16 to 3.18. Presently, this is done using the old modules and the system is performing satisfactorily. In order to upgrade this with the state-of-the-art electronic components, a new module has been developed and beam test can be done shortly. This uses RF modulation technique where both amplitude and phase of the beam are in quadrature modulated and fed to a spiral cavity phase detector which resonates at 48.50 MHz.

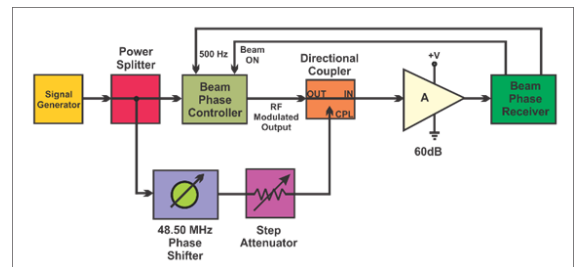

**Figure 3.16:** Block diagram of phase control electronics test setup.

**3.1.6.7 Development of RF parameters monitor for HCI**

In order to tune the various cavities of the HCI, it is essential to monitor the reflected power level signal and corresponding cavity RF pickup signal from the cavities at a time in a multichannel oscilloscope. A 8 into 1 RF Multiplexers to monitor RF reflected power and cavity pickup signals of the selected cavity have been made and installed in the High Current Injector facility at IUAC. These modules are extremely useful in ensuring HCI-RF cavities are optimally tuned during beam acceleration and facility tests. Important feature of measuring the phase of the selected cavity with reference master clock has been provided. It offers the option of selection between local and remote operation. Two such modules, one dedicated for 48.50

### 3. RESEARCH SUPPORT FACILITIES

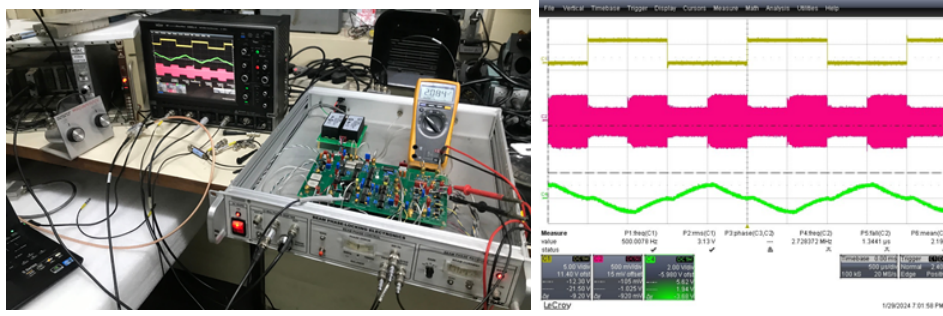

Figure 3.17: Pelletron beam phase locking electronics and test results.

MHz signals and the other for 97 MHz signals have been developed and will be installed in HCI. Analog Devices model EV1HMC253AQS24 RF switch with associated control electronics is used as RF multiplexer and AD8302 Phase Detector module is used for phase detection of the selected cavity.

#### 3.1.6.8 Development and installation of LLRF controls for spiral bunchers of HCI

Two sets of amplitude, phase, and frequency tuner controls for Spiral Buncher cavities #2 and #3 have been developed, tested, and kept ready to install during last year. They were installed in beam line with proper RF cables routed to connect the Master clock. Remote testing of all RF cavities was done during the HCI-Linac testing by arranging the required electronics. Two LLRF-VME Interface modules have been developed for this purpose and tested during the beam tests.

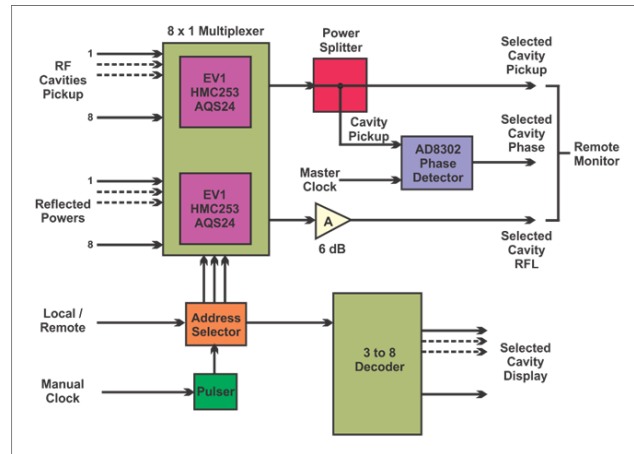

Figure 3.18: Block diagram of 8 to 1 RF multiplexer to monitor cavity parameters.

#### 3.1.6.9 Chopper and deflecting system electronics of HCI

As the HCI Chopper and Deflecting System (HCI-CAD) was developed (Fig. 3.19) and tested with the LEIBF facility to verify the deflection of the beam with DC voltage on the deflecting plates during 2016-17. A lot of effort was put in by the member along with BTS group members, who were involved during the initial development of the system particularly in searching and finalizing the electronics needed for the system. This year the complete electronics for two pairs of deflecting plates have been procured, assembled and tested in the laboratory to verify the required parameters needed for beam tuning. The electronics includes the Fast Square Wave Pulsers and dielectric cooling system for power switching devices, high voltage and control voltage power supplies, Pulse generator with the provision of four simultaneous outputs with the facility of adjusting the delay between the outputs, etc.,

After the necessary connections were made, the HCI-CAD system was prepared for testing by applying HV pulses to its deflecting plates. Currently, the system is equipped with SHV connectors for applying HV pulses; however, the manufacturer advises against using SHV cables and instead recommends replacing them with a vacuum feed-through. Since it was chosen to test the system without a vacuum at first, we have connected the Pulser outputs to the deflecting plates using solid copper sheet that was 10 mm wide and less than 1 mm thick to ensure low inductance.

The deflection plates have been simulated (Fig. 3.20) with a set 10pF/3kV RF type high voltage ceramic capacitors and powered up to 1000V at 2MHz repetition rate for the initial testing. Upon verifying that the HV pulse rise / fall times are under 10 ns, the deflecting plates were connected and powered upto 1000V at 2MHz repetition rate. The rise/fall times measured were similarly less than 10 ns and testing for a full 48 hours will be completed soon. After successful completion of this test, the electronics for the remaining two plates will be proposed and purchased.



Figure 3.19: HCI-CAD system at various stages of its testing in the lab.

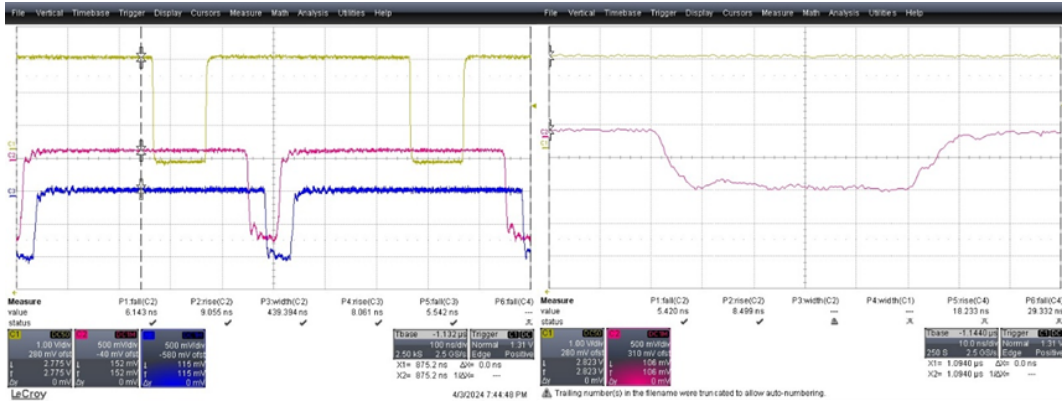

Figure 3.20: HCI-CAD system test results.

### 3.1.6.10 RF systems for Delhi Light Source

The RF system of FEL consists of a Klystron based 25 MW high-power RF source operating in pulsed mode for 4 $\mu$ s pulse duration to power a 2.6 cell, 2860 MHz RF photo cathode gun. In order to control the amplitude and phase of the RF field in the cavity during 4 $\mu$ s of operational time, commercial LLRF modules from M/s. Instrumentation Technologies were procured along with the master clock distribution module. The modules are tested in open loop feed-forward mode and commissioned with high-power RF power systems. An EPICS-based control scheme is developed and operationalized for testing. Feed-forward pulse ramping has been tried to reduce the problem of anticipated a high level of reflected power from the cavity during initial powering stages.

**Development, installation and commissioning of hardware and software:** RF and Area Interlock Scheme comprising of Water flow interlock and door interlocks [FEL and HCI both] for effective RF conditioning. Under this activity, the RF cavity's chiller was interlocked with the Modulator System Trigger control using the EXTERNAL INTERLOCK facility. The low power RF was also interlocked in software in case the chiller is found not found. Area interlock has also been implemented as per the AERB guidelines. This interlock is ANDed with Chiller interlock to produce the final interlock. In case of failure, the current status of both interlocks is visible in the control room with an option to bypass the area interlock (with the advice of Health Physicist only). This interlock system also secures the HCI beam hall area since the radiation from FEL was detected in HCI as well.

Development of Process code for Completely Automated Conditioning of RF cavity of FEL using Predictive Machine Learning techniques. This implementation has been done with a purpose of automating the process of RF conditioning to prevent recurrent system interlocks due to vacuum distortions. Pressure /

### 3. RESEARCH SUPPORT FACILITIES

---

current data from various Ion-Pump Controllers (especially from klystron tube, circulator and RF cavity) are clustered using K-means clustering algorithm and a Decision Tree Classifier algorithm is used to classify various conditions based on which a Python 3 program controls the RF input to the system for conditioning. The system is currently operational and provides fully automatic conditioning option. Under this mode, the program controls entire modulator activity using an EPICS server over Modbus - TCP protocol, even reviving from an interlock (if it happens).

**EPICS based Remote Control System:** the FEL control system has been made EPICS compatible with most of the sub-systems like LLRF, BPM, VME, Modulator, Cavity Chiller and Equipment Control being done through EPICS client-server. This year, EPICS interface was enabled for Klystron Modulator, Cavity chiller, additional BPM and VME with the help of REC and FEL group.

**Breakdown Maintenance of High Voltage Power Supplies and Switching Units** due to failure of protection diodes and IGBT switch. Two breakdown / corrective repair activity was taken up in April 2023 and October 2023. In both instances IGBT3 of SU2 and a protection diode in CCPS1 was replaced. In addition to breakdown maintenance, a periodic Upkeep and Maintenance of High-Power RF System & modulator water Chiller Systems (with Water/HVAC System) was done throughout the year on fortnightly / monthly basis. This included dry cleaning of all the air-filters of chillers and modulator along with change of water in the chillers.

#### 3.1.7 Health physics

Debashish Sen, Sejal Chandna and Birendra Singh

The preliminary duty of the Health Physics group of this centre is to ensure the radiation safety of the IUAC radiation workers and maintain AERB prescribed rules and regulations. The personnel monitoring system and the area monitoring set up are taken care of by this group. To keep a vigil on the overall radiation safety, routine maintenance of interlock system and radiation monitors is also carried out regularly. Creating awareness related to radiation safety among the radiation and non-radiation workers (by holding different orientation programmes) is another duty of the radiation safety officers. Apart from these, user support is provided to different radiation safety related research and development work conducted by different Universities & Institutes.

**Personnel monitoring:** The TLD/neutron badge service went smoothly in 2023. The detailed dose reports of these quarters have been received in time. All the dose reports received in this period are within the permissible limit.

**Area monitoring:** Neutron monitors, which were due for calibration, were taken to BARC, and were calibrated as per AERB norms. New monitors for upcoming HCI & FEL facilities are in the process of procurement. As usual, stock checking of all the radiation sources was carried out, and it was ensured that all of these were stored in safe custody. No Radiation sources were procured in the last six months.

**Interlock systems, interlock doors, display boards:** Units which were malfunctioning, were repaired, and some of them were repositioned also, as per requirement.

**Radiation sources:** Sources (with adequate shielding) are kept under strict vigil. Stock checking of all the radiation sources has been carried out and it was ensured that all of those were in safe custody. All radiation dose records (both gamma and neutron) of IUAC radiation workers are maintained regularly. As every year, few radiation monitors were replaced, and some new were installed in new strategic locations (as new facilities are coming up in the centre). Gamma/X ray monitors/ survey meters/ pocket dosimeters get calibrated each year as per their calibration schedule. Some temporary radiation shielding was provided in different areas as per user requirement.

##### 3.1.7.1 AERB inspection and monitoring

Regulatory Inspection is one of the types of inspections conducted by AERB through which it ensures that the nuclear and radiation facilities are following the legal & regulatory requirements and licensing conditions. A self-assessment checklist is created which helps the Employer/Licensee to verify that all the safety & regulatory requirements related to the licensed activities / practices are being met, and can be used as an audit tool. The self-assessment checklist has to be filled by the Employer / Licensee of the facility in consultation with the Radiological Safety Officer (RSO) while verifying the compliance through

facility walk-downs, employee interactions, and/or document/record reviews. Such AERB inspections has been carried out successfully in the recent past.

IUAC is maintaining the highest safety rating of eSPI=1.0 (in a scale of 0.1 to 1.0) with respect to radiation safety related compliance matters from AERB. Electronic Safety Performance Indicator (eSPI) value refers to safety compliance of the institute derived using following parameters reported in eLORA for the last three years, i.e., a) Non-submission of Safety Status Report (SSR) for more than a year b) Excessive exposure cases reported c) Non-Compliance (Grey, Orange and Red) raised & d) Enforcement action taken. The maximum value eSPI is 1, which refers to no deviation, on the above parameters, is reported through eLORA for the last four years. Any reported deviation will lead to a reduction in eSPI value of the institute. IUAC maintains a 1.0 rating in all the categories.

#### 3.1.7.2 e-LORA facility of AERB

- Sending the annual safety status report of the existing gamma chamber irradiation facility in the beginning of the year. License renewed in October 2023.
- Sending the half yearly periodic safety status reports of the five running radiation facilities (Pelletron-LINAC, RBS, AMS, LEIB and NII facility) in July 2023 and January 2024.
- Continuation of submission of required documents through eLORA for the approval of two forthcoming facilities: (A) high temperature superconducting electron cyclotron resonance ion source (HTS-ECRIS) for the High current Injector (HCI) facility and (B) Free Electron Laser (FEL) based light source facility. Data pertaining to facility design and construction (with respect to overall safety) are being compiled as per ongoing correspondence / instructions of AERB.
- A detailed offline presentation was made to AERB at their headquarters in Mumbai regarding the radiation safety aspects of the upcoming HCI facility. Initiation of SCRAM buttons as per AERB directives was also planned.
- Renewal of the registration certificate for possession and handling of radioactive source(s) in sealed source facility.
- Submission of the new security plan of the radiation facilities of IUAC to AERB (and also to the nearest police station).
- Getting the Pelletron-LINAC license amended as per the updated beam line parameters.
- Renewal of the license of Pelletron-LINAC and RBS facilities

#### 3.1.7.3 Training activities

A six module (24 classes of one hour each) detailed lecture series was conducted on ‘Radiation and its safety aspects with respect to the accelerators of IUAC’ to the newly joined Scientist trainees and engineers, followed by their knowledge evaluation/ assessment (and required laboratory training).

#### 3.1.7.4 Upcoming facility requirements

Safety features planned for the FEL Facility are getting implemented. A thorough radiation survey was conducted in HCI and FEL areas, while the high voltage conditioning was ON in the FEL area. The purpose of the survey was to gather information about the increased radiation levels in the area and to decide about the limitation in access and duration of the working hours in these areas as per the regulatory limits and guidelines.

Extra lead shielding around the FEL electron gun has been put to make above HCI area more access friendly. The survey results show that the radiation levels in the HCI area are within the regulatory limits and guidelines set by AERB when the RF power does not exceed 3.0 MW. It has been found from our recent radiation survey that, while the FEL machine is powered to 3.0 MW (3.0  $\mu$ s pulse width), radiation level of <0.1 mRem/hour has been observed in the HCI beam hall, which is safe and permissible (max 0.1 mRem/hour) for all including non-radiation workers. Hence, under these conditions, entry of both radiation and non-radiation workers is allowed in HCI beam hall. However, radiation workers should use radiation badges, and non-radiation workers pocket dosimeters. Both the NLK doors are now operative.

### 3. RESEARCH SUPPORT FACILITIES

---

#### 3.1.8 Data support laboratory

Mamta Jain, Kusum Rani, Subramaniam E. T and R. P. Singh

The group maintains all the Data Acquisition Systems  $24 \times 7$  in nuclear and atomic physics experimental facilities with 100% uptime along with development of various hardware modules and softwares for DAQ and control applications to cater the need of different facilities like HCI, Radiation Biology, LINAC, INGA, NAND, HYRA, Atomic Physics, LEIBF, GPSC etc. User support for the experimental facilities is one of the primary responsibilities of the group.

##### 3.1.8.1 Operation

- Explored the possibility of acquiring data using a heterogeneous DAS (VME analogue DAQ and Digital DAQ combination), to enhance the capability of INGA by adding ancillary fast detectors like LaBr, neutron detectors etc with slow detectors such as clover, CsI etc.
- All the ROSE based DAQ systems at various experimental facilities were fully functional during the experiments.
- The ASPIRE facility was operated during the experiment in radiation biology area.
- The VGEM was fully functional in all the experiments in INGA experimental facility.
- All the BPMs are running fine in HCI beam line.

##### 3.1.8.2 Maintenance

1. ROSE-MARS based DAQ systems in the experimental facilities NAND, GDA, INGA, GPSC, HYRA, HIRA, GDA, Atomic Physics, LEIBF, 111lab, FEL  
The preventive maintenance of all the systems under the group is performed as and when required during the whole academic year so that there will not be any down time during the experiments due to Data Acquisition side. This involves timely upgradation/installation of the Operating System along with DAQ softwares like ROOT, NiasMARS etc in different DAQ facilities and the data room.
2. LPCC based CAMAC DAQ systems are maintained in HIRA-HYRA lab and Detector Lab
3. Systems in the Data Room and beam hall I and II All the systems were maintained to run the system with 100% uptime during the nuclear physics and atomic physics experiments.
  - DAQ server for remote boot of VME crate controller ROSE
  - Network router for DAQ network in beam hall I and II, which is now extended to FEL beam hall.
  - NiasWebViewer for online remote view.
  - 3 Client PCs for online data collection and offline data analysis
  - Camera, monitors /TVs with DVRs
  - Overhaul of Data room racks and network without disturbing the existing setup.

##### 3.1.8.3 Development and upgradation

The ROSE-MARS based DAQ system installed and tested in FEL area with pulser and DAQ network extended to FEL.

#### 3.1.9 Computer and communications

B. K. Sahu, Abhishek Kumar, Anand Prakash, Yatesh Dabas and Shweta Agarwal

This academic year the group had put up maximum efforts to keep the 100 percent uptime of the network connectivity and servers throughout the year. Preventive maintenance of various network equipment is carried out to avoid breakdown of network services. Continuous upgradation of desktop computers and licensed software are carried out throughout the year. This year significant progress has been done for implementing a paperless Human Resource management system. New servers are added for the access CST microwave software. Server and portal for online recruitment module is made operational. During this academic year the group has successfully accomplished the establishment of 3PF supercomputing facility at IUAC under NSM with the help of CDAC team. Highlights of these activities are mentioned below.

### 3.1.9.1 Status of servers

(a) **Central servers:** There is only one server failure during this academic year. The internal web server crashed due to hardware failure. The internal web server is regenerated using the backup available. The performance of all other servers like Enterprise Resource Project Server (ERP), Web Server (IUAC website), LMS server, email server, etc. are found to be satisfactory

(b) **CST microwave studio licensing server:** As per the requirement of IUAC, academic license for CST Microwave Studio is procured in this academic year. A new server known as CST Microwave studio licensing server is installed to provide the free-floating licensing information to the clients using CST microwave studio present in the Local Area Network of IUAC. The server has been installed on Windows 10 professional operating system.

(c) **Migration of the existing email services to the National Informatics Centre (NIC) cloud:** In the past we have seen continuous malware attacks on our mail server. In order to enhance the security of the email server, the existing email server was migrated to the NIC cloud. The data transfer from the existing server to the new server was done using the IMAP protocol ports opened towards the NIC gateway IP. In total, 180 accounts are created on the new email server having the feature of two-factor authentication.

(d) **Human Resource Management System (HRMS) server:** This academic year we have added a new server to our existing pool of central servers for the implementation of paperless Human Resource Management System (HRMS). The server is hosting the HRMS application for IUAC employees. HRMS is being developed as a paperless e-office solution for IUAC employees keeping in mind of existing IUAC bye-laws. At present, the HRMS leave management module is implemented for managing online leave applications.

(e) **Server for soul software installation:** The library cataloging, circulation, and acquisition server is installed on the IUAC server with the support of INFLIBNET, Gandhinagar. The existing server for the library is running on the KOHA server and the database migration from the currently running server to the format appropriate for the SOUL server will be done.

### 3.1.9.2 Status of network and internet services

(a) **Switch installation** As reported in previous years, we are in the process of replacing ten years old switches installed at various locations, that has been showing signs of abrupt failing. Last academic year two switches are replaced after configuration in the main office building and two more switches are procured and kept pre-configured for replacement to minimize downtime.

(b) **Network connectivity to the new data center** The New Data Center was provided the 1 Gbps network connectivity through the core switch present in the old data center to make the new High-Performance Computing cluster accessible to the users. Also, the domain name registration is done for access to the facility through the domain name for outside users accessing the facility outside the LAN of IUAC. Firewall rules were made on the firewall for opening the necessary ports

### 3.1.9.3 Communication systems

(a) **Status of new IP based PABX system:** The Hybrid EPBAX system catering to nearly 290 analog extensions along with IP based phones installed in the existing network has nearly 100% Uptime without any failure during this academic year. This year number of soft phone connections were being provided to users for having full mobility in the lab complexes and experimental areas.

(b) **Status of video conferencing systems and CCTV surveillance:** During this academic year additional IP cameras and microphones are added in the seminar hall and Ph.D. Class room for hosting lectures in hybrid mode. Many of the events listed in the academic calendar are organized in hybrid mode using physical meeting halls and on-line video conferencing using Google Meet, Webex platforms. All the installed Audio video systems in Auditorium, Seminar Hall etc. are being used as per the need and kept functional. No major breakdown of the Audio Video system was reported. This year additional CCTV surveillance is provided as per the request. Presently CCTV surveillance systems having ~150 Cameras are routinely maintained and faulty devices are replaced.

### 3.1.9.4 Developmental projects

(a) **Data storage server for archival of the data generated in various laboratories of IUAC:** A data storage server system is installed for the archival of the experimental data generated by the various

### 3. RESEARCH SUPPORT FACILITIES

laboratories of IUAC. The Data storage server has been installed as a NAS (Network Attached Storage) in RAID 6 configuration with SMB / CIFS file transfer protocols. On the client systems, an SMB client will be installed depending upon the client system OS for accessing the storage system and transferring the files.

(b) **Application portal for scientific and technical recruitment:** A portal for the online submission of applications and fee collection from the potential candidates for advertised vacant positions is designed, developed, and hosted on the IUAC server. The portal is developed on the CodeIgniter framework can serve as the standard package for any recruitment process that will happen in the future.



**Figure 3.21:** Photographs of different stages of the data centre.

(c) **Status of 3 petaflop supercomputing facility** During last academic year, civil infrastructure at IUAC was made ready for the installation of 3 PF supercomputing system and foundation stone was laid. The Installation of the data centre is completed in this academic year. The cooling equipment like dry coolers and outdoor units for the HPCC (High Performance Computing Cluster) are placed at the existing terrace of the building. The cooling arrangement consists of three kinds of cooling, Direct cooled liquid cooling, Ambient cooling using precision air conditioning, and adiabatic cooling is in place. The porta cabin of the old HPCC facility is used for housing the electrical requirements such as batteries and UPS for the new data centre. All the necessary power infrastructure having Lithium-ion batteries, UPS for IT and Non-IT load with (N+1) redundancy have been installed and made operational. Indigenously developed Rudra servers are housed in 12 special direct contact liquid cooling (DCLC) racks. There are 650 compute nodes in total with the Dual Socket Intel Xeon 2nd Gen scalable processor having 24 cores each, 4 Peta Bytes of Storage units installed along with 200 Gbps interconnect (without a splitter). HPC software stack consisting of compilers, provisioning tools, etc. have been implemented based on Open-Source Technologies. The benchmarking of the HPC cluster using the High-performance Linear equations solving program (HP-LINPACK) is being done and the nodes are currently available for carrying out computations. Access for using this computing facility will be provided to the user community soon as per the request proposal received from them.

#### 3.1.10 Cryogenics instrumentation cum machine learning laboratory

Joby Antony and Rajesh Nirdoshi

##### 3.1.10.1 Cryogenics control system and associated electronics

Throughout this year, the IUAC Cryogenics control system and related electronics have undergone preventive maintenance and have operated efficiently. It has remained in continuous operation to support MRI and Linac runs since June 2023. As depicted in Fig. 3.22, the Cryogenics control room is equipped with three control terminals for remote control, data collection, trends monitoring, operator interface, and other functions.

(a) **CADS terminal:** In addition to serving as a distributed control system, this PC also features a comprehensive historical trends utility. This tool facilitates both offline and online analysis of analog and digital parameters over extended periods, spanning from months to years. It enables the operators to analyze levels, vacuum, valve positions, pressures, and more in real-time or retrospectively. The back-end hardware



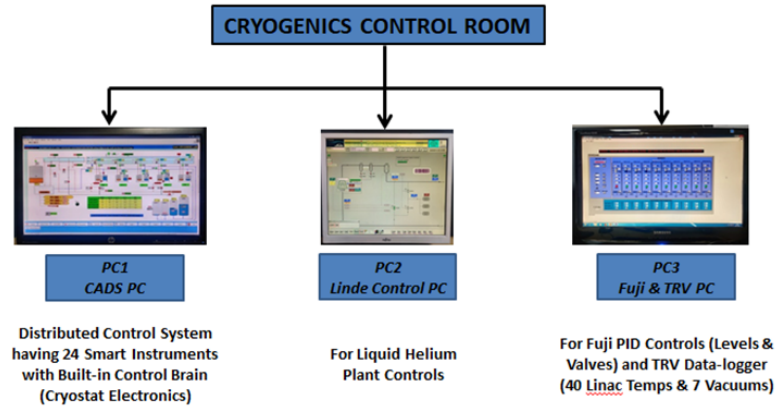

**Figure 3.22:** The cryogenic control room terminals.

comprises 24 IoT-based device servers, facilitating seamless integration with LN<sub>2</sub>, LHe sensors, soft-PID, and LN<sub>2</sub> auto control, among other functionalities.

**(b) LINDE control terminal:** Originally provided by M/S Linde Kryotechnik, Switzerland, this PC operates on Siemens software and serves as a vital standalone controller for the liquid helium plant. Unfortunately, the main control server (RMCS) experienced its second malfunction this year due to a motherboard issue. However, after significant internal efforts, the problem was resolved, ensuring its functionality for the Linac run.

**(c) Fuji and TRV terminals:**

This PC controls helium and nitrogen proportional valves in Linac cryostats using RS-232-based 9 Fuji PID controllers. Additionally, it functions as a TRV data-logger, replacing the outdated VME system. Equipped with 6 TRV devices, it monitors 40 temperatures and 7 vacuums across all 5 Linac cryostats. These devices feature accessible screens outside the beam hall for easy viewing during trials, with or without PC connectivity.

### 3.1.10.2 A 48-channel TRV data-logger for linac thermometry and vacuum

This year, a 48-channel temperature cum vacuum GUI data-logger and trend monitor software was put to use for long Linac run first time ever. It has been operational for the last 10 months. It utilizes six home-built cryogenic TRV instruments (each having 8-channels) designed to replace the VME crate system with an indigenous distributed crate-less solution for measuring 40 temperatures and 7 vacuum signals of all Linac cryostats. Additionally, it can monitor and record sensor resistance, and sensor voltage for quick debugging. This data-logger functions as an unlimited historical trends viewer and real-time viewer. To ensure accessibility, the TRV devices are located 50 meters away from the radiation zones. In addition to being cost-effective, these instruments can potentially serve as import replacements for M/S Lakeshore 218 models in the future. The snapshots of this data-logger utility are shown in Fig. 3.23.

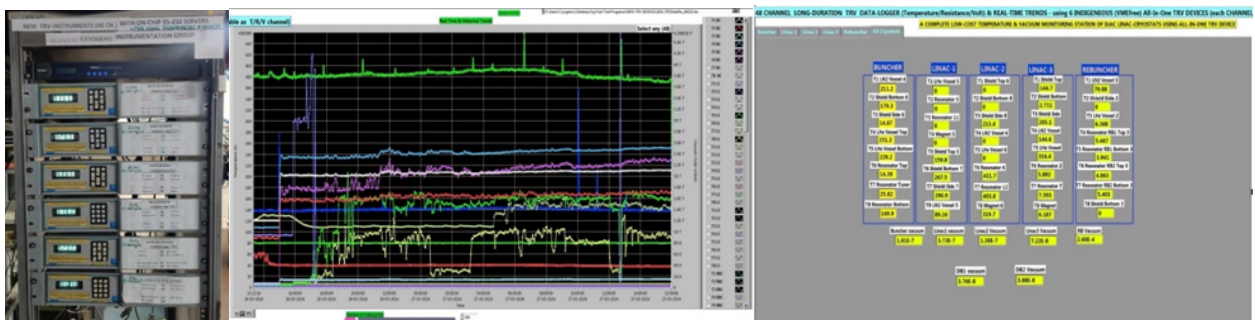

**Figure 3.23:** TRV data-logger installed in cryogenic control room.

### 3. RESEARCH SUPPORT FACILITIES

#### 3.1.10.3 Testing and commissioning of FPGA-based MRI DAQ software

This year, the LabVIEW FPGA-based fast data acquisition system software was successfully integrated and commissioned with the real MRI magnet, yielding satisfactory results. This system serves as the core of the MRI magnet and includes a quench trapper implemented in FPGA. Acting as a watchdog, the quench trapper activates during any of the eight magnet-coils quenches, storing 24 magnet parameters with a 500-microsecond timestamp in minimal storage space for future retrieval & analysis. Notably, this utility effectively captured a quench event that occurred in August 2023, as shown in Fig. 3.24.

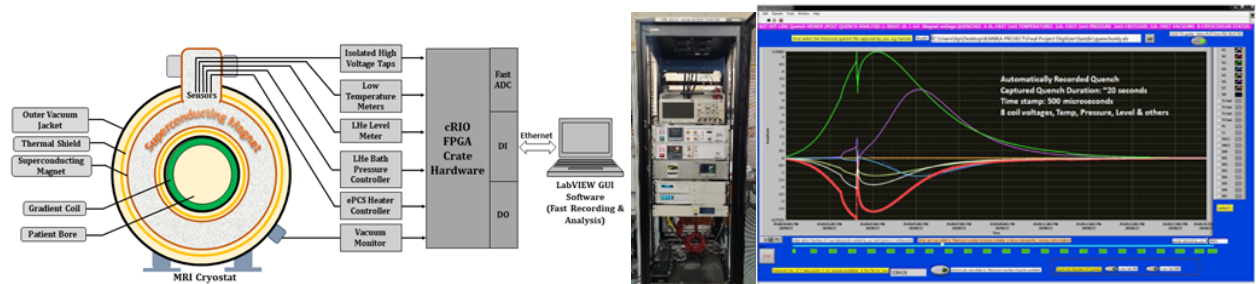

Figure 3.24: MRI DAQ connections and captured quench events.

#### 3.1.10.4 AI RNN-LSTM neural network device for cryogenic valve control

A Recurrent Neural Network (RNN) device leveraging AI-IP model has been developed to enhance closed-loop proportional valve controls. Tested extensively over 240 hours with the Linac-3 LN2 valve during the current Linac run, the device delivered satisfactory results as shown in Fig. 3.25. Testing was conducted remotely from the Cryogenic Control room.

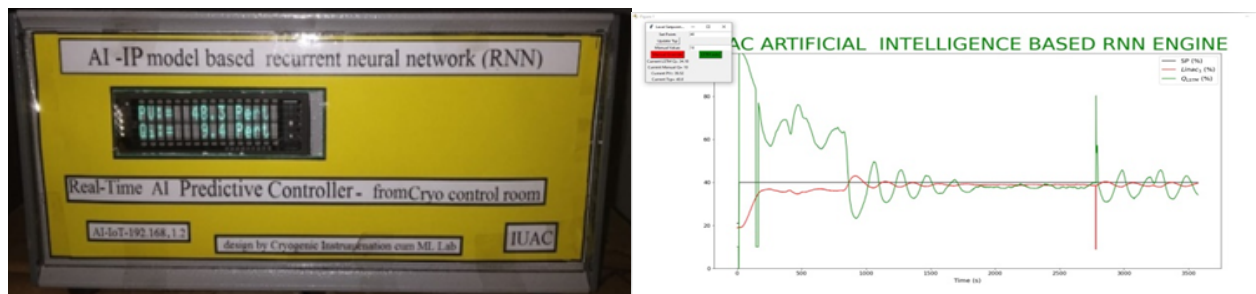

Figure 3.25: The AI-based RNN device and the test results.

#### 3.1.10.5 A low-loss AI-enabled cryogenic level monitor

A low-loss AI-enabled Cryogenic Level monitor (Fig. 3.26) was developed utilizing superconducting level gauges to minimize Helium losses. This underwent practical testing during the Helium plant run, specifically with a 1000 L Dewar sensor. The system integrates AI/IoT technology to enhance efficiency and reduce LHe evaporation. Employing ML techniques, the device operates with the single 85 cm superconducting level gauge and incorporates a HV current source (+72V power supply) with a pulse sampler for optimal performance. It is an AI “AutoML” device embedded with a machine learning model that automatically reduces unnecessary heat pumped to the sensor, further enhancing its effectiveness.



Figure 3.26: A low-loss AI-enabled cryogenic level monitor.

### 3.1.10.6 AI-safety device and AI-based audio classifier for MRI

Our laboratory has developed two innovative devices aimed at enhancing safety and efficiency in MRI: an AI-safety device and an AI-based audio classifier.

The AI-safety device incorporates advanced technology to ensure safety within the MRI environment. It features a magnetic field announcer, which provides audible safety warnings to alert personnel of potential risks. Additionally, the device is equipped with an automatic email notification system triggered by AI person detection, enabling real-time alerts for enhanced security. With IoT connectivity, the AI-safety device offers seamless integration with existing systems for comprehensive safety management. This device is shown in Fig. 3.27.



**Figure 3.27:** AI-safety device mounted on instrumentation rack in MRI room.



**Figure 3.28:** AI-cryocooler audio classifier unit.

AI-based audio classifier utilizes neural network technology to analyze specific sound patterns emitted by the cryocooler. By processing and classifying these audio signals, the classifier accurately predicts whether the cryocooler is operational or offline, as depicted in Fig. 3.28. This predictive capability aids in proactive maintenance scheduling and ensures uninterrupted functionality of MRI.

### 3.1.10.7 Critical power outage IoT edge device server

Our laboratory has engineered a cutting-edge solution to address the challenge of unwanted power failures in various facilities at IUAC. This innovative device (Fig. 3.29) serves as a proactive safeguard against power disruptions by continuously monitoring the power supply to connected systems. In the event of a power outage, the device promptly detects the interruption and autonomously transmits a notification to the designated receiver unit. This real-time alert prompts immediate action, empowering the concerned person to swiftly implement appropriate measures to mitigate the impact of the power failure.



**Figure 3.29:** Power outage IoT edge device server and receiver unit.

By leveraging IoT technology, power outage IoT edge device server enhances operational resilience and minimizes downtime for critical infrastructure. Its proactive approach to power outage management ensures uninterrupted functionality and helps safeguard against potential disruptions, thereby optimizing operational efficiency and reliability.

### 3.1.10.8 Other major activities

- The Indian Patent Office granted patent [1] for an apparatus invented by Joby Antony and patented by IUAC. This invention involves an apparatus for continuous LN<sub>2</sub> level measurement and control in cm accuracy using capacitive sensors and real-time closed-loop control using IP based embedded-server, easy in-situ calibrations capability, low Bandwidth IoT device-server.
- Instrument repair support was provided for the LN<sub>2</sub> plant issue at NPL. After consultation, the PLC CPU module was repaired in-house, successfully resolving the problem.
- Our laboratory has received a technology transfer request from M/S Scientech, Indore for the AI-based experimental designs. It has been approved and the technology transfer process has been initiated.

#### References:

1. Apparatus for nitrogen level sensing, Patent No. 438160, 11/07/2023, The Patent Office, Govt. of India.

### 3. RESEARCH SUPPORT FACILITIES

#### 3.1.11 Ion source group

Radhakishan Gurjar, Mukesh Kumar and Ambuj Tripathi

The Ion Source Group is an Accelerator Facility Central Support Group (AcSCG), which takes care of the activities of ECR Ion sources on high voltage platform and associated electronics including High voltage power supplies (HVPS), Light Link Interfaces, HTS Coils related electronics, system operation and maintenance. The group also provides technical support to other groups regarding HVPS and development activities.

##### 3.1.11.1 Preventive maintenance schedule of ISG instruments

The group performs yearly scheduled preventive maintenance of every instrument to preserve its life, performance and to ensure breakdown-free operation during the yearlong continuous operation.

**(A) LEIBF ion source:** The Deck High Voltage power supply was cleaned and checked the all loose connections in power supply. Bleeder of deck high voltage power supply was cleaned. Insulator of deck and extractor area were cleaned. Fiber optics modules and fiber cables were cleaned.

**(B) HCI ion source:** The GP tube of HCI Ion Source was filthy. This situation was occurred due to carbon deposition. The GP tube's resistance was showing in the range of  $M\Omega$ . Generally, the GP tube resistance should be infinity or greater than  $5\text{ G}\Omega$  per column for better sustained high DC voltage. After cleaning, the GP tube resistance was showing higher than  $5\text{ G}\Omega$ . The resistance of each columns in GP tube were showing between  $120\text{ G}\Omega$  to  $250\text{ G}\Omega$ .

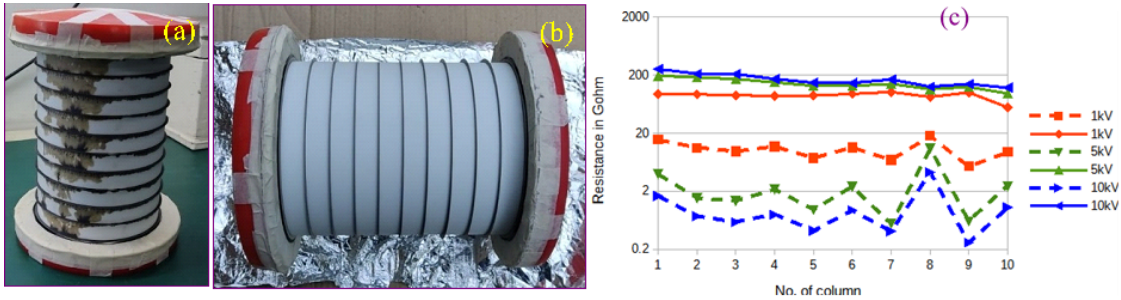

**Figure 3.30:** (a) GP tube before cleaning, (b) GP tube after cleaning and (c) graph of resistance measurement at different voltages.

##### 3.1.11.2 Breakdown maintenance of ISG instruments and ECR source

###### (A) LEIBF:

The LEIB facility did not run smoothly for the past 2 to 3 months (from March 23 to May 23). During the user's experiments, the deck voltage did not remain constant. There were more fluctuations in the deck voltage. The deck's voltage fluctuation was caused by two factors: GP tube and ECR ion source.

**1. GP tube cleaning:** The GP tube was seen dirty on the ceramic area. This situation occurred due to carbon deposition. We measured the resistance of the GP tube using Megger. The all registers of GP tubes were removed before measuring the resistance. The GP tube's resistance was showing in the range of  $M\Omega$ . Generally, the resistance of GP tubes should be infinity or greater than  $5\text{ Gohm}$  per column for better sustained or hold high DC voltage. The GP tube was cleaned through sandblast, water jet (DI water), dip in alcohol and baking in oven. All GP tubes were cleaned and their resistances showed a significant increase of around  $95$  to  $240\text{ G}\Omega/\text{column}$ . After cleaning all the GP tubes, leak test was performed. No leak was found.

Finally, all 5 GP tubes were reinstalled in the beam line of the LEIBF. The GP tubes conditioned with Deck voltage from minimum to high voltage ( $20\text{ KV}$  to  $200\text{ KV}$ ). We tested the stability of the deck voltage with the argon beam under different charge states. Finally, all GP tubes are capable of sustaining or holding up to  $200\text{ KV}$  Deck voltage. The LEIB facility is ready to use for user experiments.

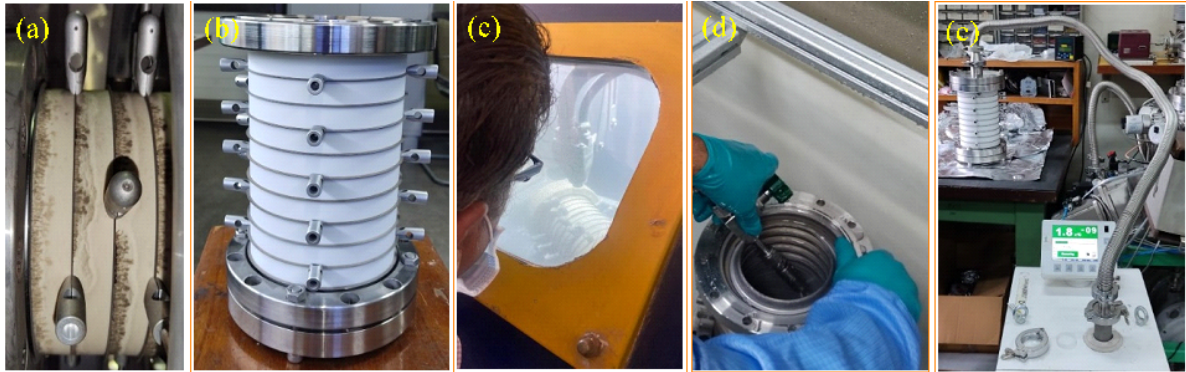

**Figure 3.31:** (a) GP tube before cleaning, (b) GP tube after cleaning, (c) sandblast cleaning, (d) water jet cleaning and (e) leak testing.

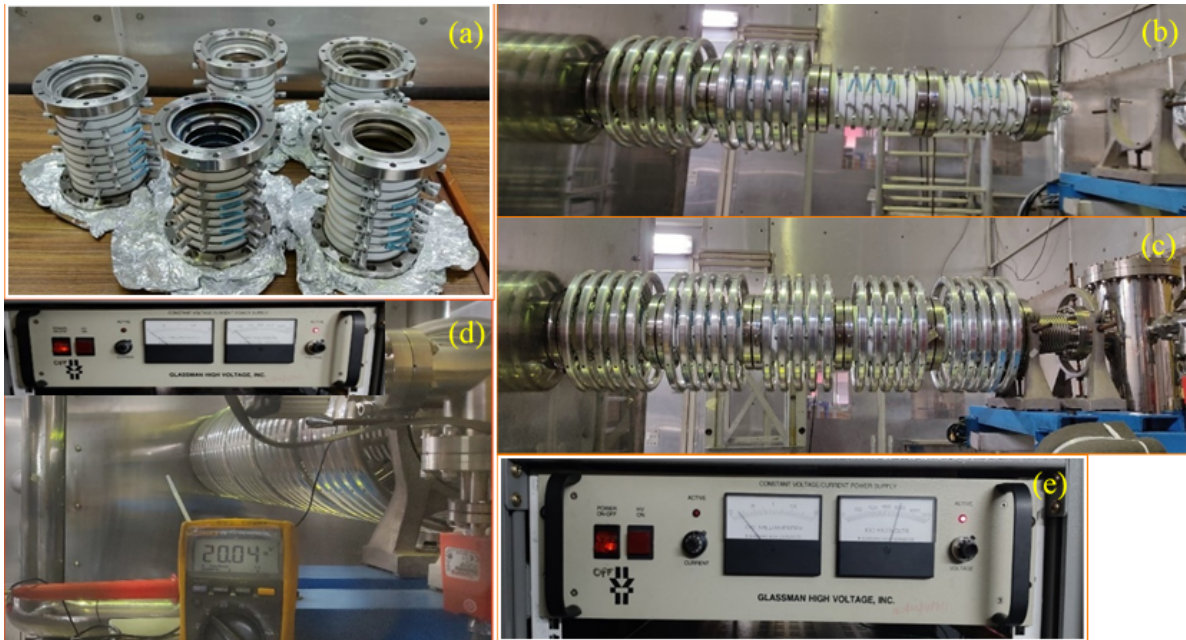

**Figure 3.32:** (a) Clean GP tubes, (b) re-installation of GP tubes, (c) reinstalled GP tubes, (d) Deck HVPS operated at 20 kV and (e) Deck HVPS operated at 200 kV.

## 2. ECR ion source:

The following four steps for clean and maintained of ECR ion source: Dismantle, Clean, Re-assemble and Testing. Before dismantled ECR ion source, remove all HVPS connections and closed the vacuum. The all parts were dismantled step by step.

All the dismantled components of ECR ion source were cleaned. These components were cleaned using alcohol and lint free tissue paper. Extractor side insulator was cleaned by the sandblast.

The source and associated components of ECR ion source were cleaned. The all components and parts were re-assembled step by step in reverse direction of the dismantle process. The cleaned platform of ECR ion source and connected all high voltage power supplies. Start the vacuum of ECR ion source platform.

### Repair of +300 kV, 2 mA deck HVPS:

The stack PCB of Deck voltage is subdivided in two part. First is lower part and the second is Upper part. The lower stack PCB was burnt through inject. The components (diodes) burnt in the lower PCB. The dismantled stack of the deck HVPS. Cut out the burnt portion in lower PCB & new PCB fixed by araldite. The diodes were mounted on the lower PCB. The araldite portion dry using fan for 24hours. Re-assembled stack in deck HVPS and tested Deck high voltage power supply. Finally, the Deck HVPS is working fine.

### 3. RESEARCH SUPPORT FACILITIES

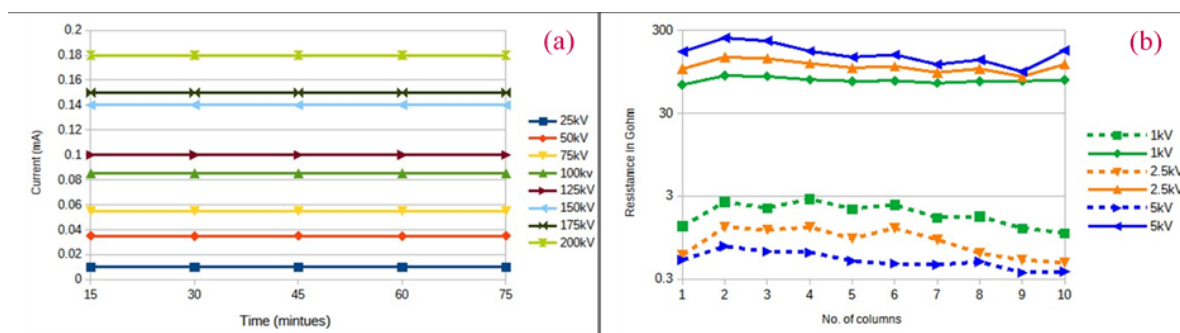

**Figure 3.33:** (a) Stability test graph of deck HVP and (b) graph of resistance measurement at different voltages.

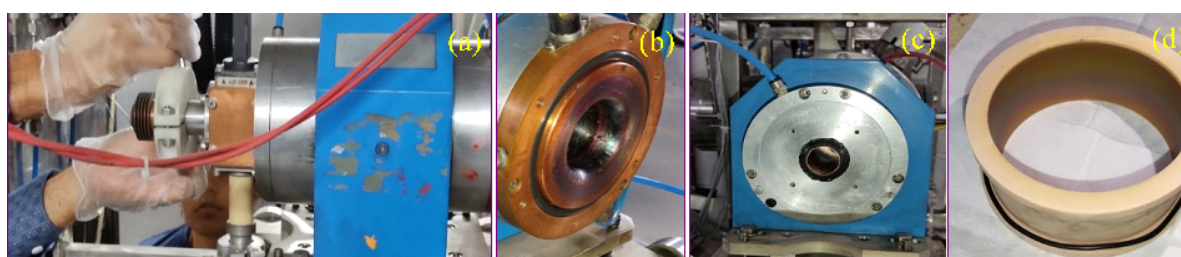

**Figure 3.34:** (a) Dismantled components of the ECR ion source, (b) extractor flange before cleaning, (c) O-ring of injection side and (d) extractor side insulator before cleaning.

#### (B) HCI:

**Repair of extraction side compressor:** The extraction side's cold head motor (CHM) was not functioning. The supply voltage of the cold head motor at the power supply was checked. The capacitor, solid state relay and input voltage of the CHM were checked. The cold head input voltage and components were satisfactory, so we made the decision to open the cold head motor on the extraction side. Removed the cold head extraction motor. The cold head motor was damaged. The defective motor was replaced with a new one.



**Figure 3.35:** (a) Faulty cold head motor of extraction side compressor and (b) repaired motor.

#### 3.1.11.3 Support activities

**1. Repair of power supply of electron gun (2 kV) for Penning trap:** This power supply is used for ionizing atoms in the penning (ion) trap. In this power supply, the source voltage was not coming. The problem was found in the two electronics modules.

Source module – IC was not working. Diode was burnt. IC and diode were changed.

Auxiliary Power supply module – Supply voltage +15V was sparking. Voltage regulator IC 7815 was dry soldering. Properly soldering of IC 7815 was carried out. Finally, the electron gun power supply was made to work.

**2. Repair of high voltage DC power supply for Amity University (60 kV, 1 mA):** This power supply is used in Amity University. The HVPS was functioning properly, but there was an issue with calibration. The output voltage and voltage display were not in synchronization. The output voltage (real o/p) was a major difference when compared to the panel voltage display. The variance in voltage between output voltage and panel voltage display is about 6kV. The problem was observed in the voltage multiplier unit. The multiplier section cannot be opened due to the Araldite covering this unit. If we open the multiplier section, then break the components and other parts. So, we have not opened the voltage multiplier unit. The display window's limitation was adjusted using a potentiometer and some resistance adjustments. Then there was a minor difference between the supply voltage and the display voltage. Around 0.1 kV was the offset. The power supply is now functioning properly.

### 3.1.12 Remote control electronics laboratory

Rahul Rai, Deepak Kumar Munda, Ruby Shanthi and Kundan Singh

#### 3.1.12.1 High current injector

The HCI beam line has been coupled with the existing zero degree beam line at the entrance of linear accelerator (Linac) modules. Almost all the installed beamline components are controlled or monitored from the control console located in the control room. We have adopted server/client technology, where servers are installed close to the beamline components and communicate with client(s) via TCP/IP protocol. The Remote Control (REC) lab is involved in developing the hardware and software for remote control-n-monitoring of beam line components, viz. faraday cup (FC) controls, beam line valve (BLV) controls, beam line pressure monitoring, magnet power supply controls, controls of RF cavities (DTL), quadrupole (RFQ) and spiral buncher etc. We have adopted high density VME bus based control hardware and indigenously developed all kinds of control modules, and VME bus controller, which are required to run the facility. To protect these high density VME I/O modules, spike suppressing circuitry is developed indigenously in a modular form and housed in a 4U height chassis. The total number of signals routed to the control console are summarized in Table 3.2.

**Table 3.2:** VME Crate system with bus controller and I/O modules in different locations of the beam.

VME servers	Output register	Input gate	Scanning ADC	DAC	Total
High voltage DECK (HVDECK)	27	23	44	21	115
After GP tube (AGPT)	112	145	97	44	398
High energy beam area (HEBT)	57	105	36	9	207
Total	196	273	177	74	720

#### 3.1.12.2 CAMAC-to-VME system migration with Pelletron at the vault area

After successfully completing the control electronics i.e CAMAC server to VME server, migration at 255-Level and Ion source of Pelletron machine, the Up-gradation of CAMAC server at Vault area of Pelletron is planned and all necessary control modules are made in VME form factor viz. IGOR2, qScanner etc. The VME server housing all necessary modules is tested in the lab for a duration of one week continuously. The monitoring log is prepared and scheduled to install in the beam line in next tank opening.

#### 3.1.12.3 Remote control related work at FEL facility

- Remote control and Monitoring of FEL beam line cavity chiller parameters at FEL control room using EPICS based servers.
- RS232 based servers installed in FEL for the Remote control for steerer and bending magnets power supplies.
- EPICS based VME server software installed and prototype tested with VME based ADC , Input Reg and O/P Reg. One RS232 server based prototype for slit- motor controller tested.

#### 3.1.12.4 Indigenous double slit assembly

- Control electronics will be designed by REC lab.
- IUAC workshop group has the responsibility of designing a complete Mechanical assembly.
- At present the REC lab has tested one ARM assembly for functionality.
- The final PCB design is in process.

### 3. RESEARCH SUPPORT FACILITIES

---

#### 3.1.13 Analog nuclear instruments

Arti Gupta, S. Venkataramanan and P. Sugathan

**Maintenance of INGA Clover electronics modules:** During this year more than 16 Clover electronics modules, which are part of INGA array, were taken up for preventive maintenance. They were thoroughly cleaned for dust and clogged filters. The NIM crates as well as air cooling units were also taken up for preventive maintenance. All the modules were restored and tested with a nuclear pulser in laboratory and any minor problems observed were rectified.

### 3.2 Utility systems

#### 3.2.1 Electrical group activities

Raj Kumar, Gaurav Singhal and Mohd. Arif Waqar

Electrical system of IUAC is having following power source installations:

Electrical Sub-stations:

- 11/0.433 kV Main sub-station of 4.5 MVA capacity having two HT supply – 1 No.
- 11/0.433 kV Packaged compact sub-station of 1.6 MVA – 1No.
- 11/0.433 kV Packaged compact sub-station of 1.0 MVA – 1No.

DG Sets:

- 3x750 kVA DG Sets synchronized and controlled through PLC.

UPS Systems:

- 3x300 kVA true online UPS System – 1 Set
- 3x60 kVA true online UPS system – 3 Sets
- 2x60 kVA true online UPS system – 1 Set
- 3x200 kVA true online UPS system – 1 Set

Solar Power Plants:

- Grid interactive solar power plant of 100 kWp capacity- 1 No. (Owned and maintained by IUAC)
- Grid interactive solar power plant of 120 kWp capacity- 1 No. (Owned and maintained by external agency)

Servo Voltage Stabilizers:

- 415 V, 3 Phase, 1000 kVA – 1 No.
- 415 V, 3 Phase, 500 kVA – 1 No.

Apart from above power sources we have following electrical power & lighting systems:

- Normal power distribution panels
- DG power distribution panels
- UPS power distribution panels
- Lighting distribution panels
- Light fittings and fixtures
- Street and compound lighting
- General earthing and dedicated clean earthing systems
- Power factor compensation panels

All the above electrical installations have been working satisfactorily during the year with 100% up-time.



### 3.2.1.1 Maintenance activities

Maintenance of all above electrical installations has been carried out as per schedule during the year.

Besides the day-to-day routine maintenance following major schedule maintenance works are carried out annually.

- RMU service for the packaged substations.
- Servicing and calibration of all protective relays of HT and LT Panels.
- Dehydration of transformer oil for 6 Transformers.
- Servicing of all OCB and ACBs.
- Annual servicing of DG Sets.

### 3.2.1.2 Maximum demand and power consumption during 2023

The maximum demand during the year has been at 1680 kVA in July 2023 and minimum demand observed was 930 kVA in Feb 2023. Monthly demand chart is shown in Fig. 3.36.

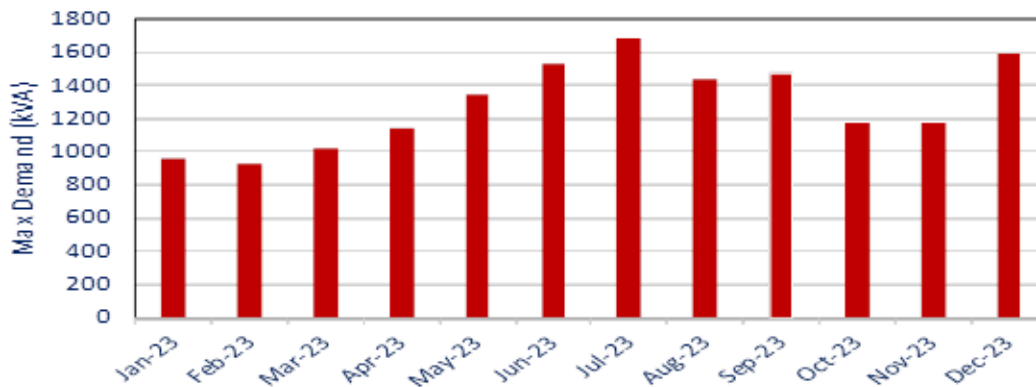

Figure 3.36: Power consumption chart for 2023.

### 3.2.1.3 Installation of 3 × 200 kVA true on-line UPS systems

We have successfully installed 3 × 200 kVA UPS systems this year in N+1 configuration. These UPS systems will feed load to pelletron accelerator, beam hall-1 and 2 experimental facilities, all 3 floor load of main lab building and free electron laser facility.

### 3.2.1.4 Replacement of HPSV street and compound lighting into LED lighting system

This year we have replaced all streetlights and compound light system from HPSV light to LED light fittings. This will offer 50% power saving in the coming years

### 3.2.1.5 Electrical works for 3 PF data centre

All electrical works required for 3 PF Data Centre has been completed successfully during this year. The total load of the facility shall be 718.5 kW. The main components of the systems are following:

- 2x500 kVA On-line UPS Systems with Lithium-Ion batteries having 30 min power back-up
- 2x150 kVA On-line UPS Systems with Lithium-Ion batteries having 30 min power back-up
- Main electrical panel suitable for 1000 kVA power.
- Other UPS output LT Panels for power distribution.
- Overhead bus ducts for servers and storage racks

### 3. RESEARCH SUPPORT FACILITIES

#### 3.2.1.6 Rooftop solar system

IUAC owned roof top grid interactive 100 kWp (2\*50 kWp) solar power generation plant is operational and maintained in healthy condition. Total power generation of year 2023 has been 1,14,792 kWh. Maximum monthly power generation during the year has been 13,602 kWh in the month of June 2023. Periodical maintenance and cleaning of solar PV panels is carried out throughout the year to get maximum power out of it. We have already recovered capital investment on this plant within 4 years of generation. Monthly generation chart of the plant is shown in Fig. 3.37.

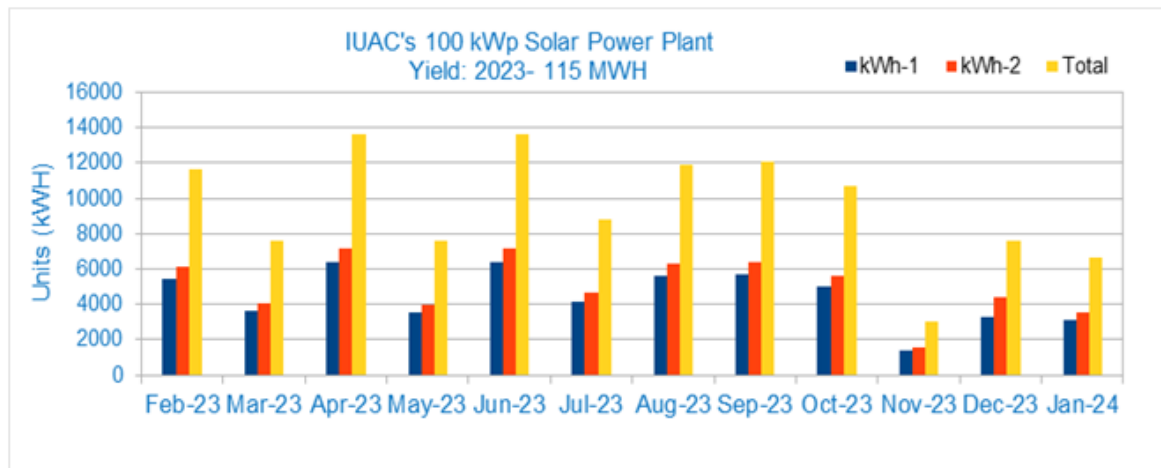

Figure 3.37: Solar power production chart for 2023.

#### 3.2.1.7 Power factor compensation

There are following power factor correction panels in our distribution system.

- 350 kVAr, 7 stage power factor correction panel – 2 Nos.
- 300 kVAr, 7 stage power factor correction panel – 1 No.

Electrical group is very happy to declare that yet again we achieved average power factor of  $>0.99$  lag for the year. Our system power factor without correction is about 0.85 lag. This has been possible due to regular upkeep of power factor correction capacitors, contactors and other switch gears of the panels.

#### 3.2.1.8 Fire detection and alarm system

There are following fire detection and alarm systems installed in IUAC.

- Addressable fire detection system at Auditorium
- Addressable fire detection system at 2nd floor lab complex.
- Conventional fire detection systems at main lab building, LEIB building, new guesthouse, Beam Hall-3, engineering building, Beam Hall-2 stores.

All the above fire detection and alarm systems are in healthy condition and are being maintained regularly through AMC.

### 3.2.2 Air conditioning, cooling equipment, water, compressed air and fire hydrant systems

Bishamber Kumar and S. S. K. Sonti

#### 3.2.2.1 Airconditioning system

IUAC's central air conditioning / low temperature cooling system of Phase-1, AC plant performed with 100% up time. Maintenance ensured that the safety record of the plant was maintained at 100% and the power consumption kept at optimum level.  $2 \times 250$  TR chillers installed in 2013 have run 45000 hours each.  $2 \times 250$  TR chillers installed in 2023 have run 3900 hours each.

The Phase-II and III screw chiller based central AC plants performed to an up time of 100%.

The highlight of the operation and maintenance of the above systems is the in-house supervision, optimisation of operation parameters, timely maintenance of rotating machinery and electricals led to least breakdown time and significant savings in operation and replacement costs.

#### 3.2.2.2 Water system

IUAC's centralized water system of Phase-I feeding low temperature cooling water having a total heat removal capacity of 115 TR performed to an operational up time of 100%. This is due to the stringent maintenance practices, which were followed over the years. The system has overshoot 210000 hours from its expected life span.

IUAC's centralized water system of Phase-II&III feeding low temperature cooling water also performed to an up time of 100%. Pumping system for supply of process water to HCI beam hall-III is in operation.

A strict monitoring on the water quality has ensured that the flow paths are in healthy condition. The maintenance costs were kept significantly low as compared to world class bench mark values.

150 KLD Sewage Treatment Plant (STP) performed satisfactorily. This has led to saving in water cost upto 10% of the billed cost.

Uninterrupted potable water has been made available to IUAC campus through the MCD supply and in house borewells.

Gardening water has been provided for campus horticulture work by supplying the reprocessed water conserving the potable water.

#### 3.2.2.3 Cooling and heating system

Availability of portable water chillers, water coolers, window / split / package air conditioners, electric water geysers etc. was recorded at 99%. With in house maintenance, there is significant saving the cost.

#### 3.2.2.4 Compressed air system

Compressed air plant ( Ph-I&II ) consisting of 3 nos. of screw compressors each of 150M<sup>3</sup>/Hr capacity, 4 nos of air dryers, pre/fine/oil removal filters with capacity of 2500 lpm @ 9.00 Kg/cm<sup>2</sup>, Storage Tank of 25 cum have been maintaining uninterrupted air supply to IUAC Lab campus round the clock throughout the year. Pneumatic connections are provided to different labs / area / instruments as and when required.

#### 3.2.2.5 Fire hydrant system

For Fire safety purpose pressurised water hydrant system including underground Water tank, electric / diesel engine water pumps have been installed. With this continuous water pressure is maintained in the water hydrant line. Wet risers, down comers, hose reels, hose pipes, boxes, hydrant branches have been provided in and around different buildings i.e. Material Science building, Engineering Building, New Guest house and auditorium.

### 3. RESEARCH SUPPORT FACILITIES

---

#### 3.2.3 Mechanical workshop

G. K. Chaudhari, S. K. Saini, T. Verugheese, K. K. Mistri, B. B. Choudhary, D. K. Prabhakar, Naresh Kumar and S. Ghosh

The Mechanical workshop consists of the machine shop, the welding shop, the electron beam welding machine and Mechanical design department. The primary responsibility and mandate of the Mechanical Workshop is to perform the design, drawing, followed by the parts to fabricate, assemble and commission of various mechanical devices related to accelerator, beam line, experimental and other projects of IUAC. To share the responsibilities to perform various activities, a few sub-groups are formed from the group personnel of MG-III.

The job requests for the mechanical components/devices are received through e-mail. Then the jobs are diverted to design department for preparation of engineering design, drawing, if needed, or are sent directly to the shop-floor for machining and fabrication.

Besides executing these routine jobs, MG-III Group is also responsible to take care of the Elevator, Overhead Cranes, Management of the Fire Extinguisher, various types of Industrial Gas cylinders and to execute the shifting jobs of various heavy items inside the laboratory.

There are total seven operators working in the workshop and the welding shops and they all are ITI machinist, and welder.

##### 3.2.3.1 Mechanical workshop

The major facilities in the workshop are Machine shop and Welding shop.

**Machine shop** is equipped with four conventional Lathe machines, two Milling machines, a Radial Drilling machine, a cylindrical grinder, a tool and cutter grinder, a horizontal and a vertical Band Saw machines. In addition, IUAC workshop has a five axis Vertical Machining Centre and a CNC Lathe machine. Most of these machines are of renowned brands like HMT, Batliboi, BFW. In recent past, the Vertical Machining Centre (VMC) had developed some problems and was not in working condition. As the machine was old so it was not easy to repair it as its spare parts was rarely available and was expensive. Now this machine has been repaired and has started functioning. Another CNC Lathe machine has also developed problems and is not functioning at present. The effort is being dedicated to repair it as soon as possible.

**Welding shop** is having high quality TIG and MIG welding machine. TIG welding machine has pulse TIG feature for welding of thin sections. An Air plasma cutter machine is also available to cut Stainless steel material of thickness up to 40 mm. Conventional Oxy-acetylene cutting and brazing set-ups are available for cutting and brazing related jobs.

In order to accomplish various types of mechanical jobs in a time bound fashion and to utilize resources in effective manner, a centralized tool/spares store has been formed to issue tools and spares for workshop and welding shop operators.

This year IUAC Mechanical workshop has completed more than 300 jobs requests which are equivalent to more than 3000 nos of components. We fabricated and installed all the components of HCI beam line, FEL beamline, other experimental facilities and MRI project. Several vacuum chambers, beam line components, drift tubes and other miscellaneous components were machined/fabricated from SS304/316L and other nonferrous materials.

As of today, the entire requirement of machining, welding and assembly is fully carried out by the IUAC workshop without any outsourcing.

#### Design department

T. Varughese and D. K. Prabhakar

This department designed various components and prepared drawings of various parts and systems. Among them, the design and drawings of various parts of the beam line of Free Electron Laser and High Current Injector is noteworthy. In addition to this, the design department also accomplished the designing and drawing of a few components of the experimental chambers, H-Dipole magnet for 1.2 MeV Cyclotron project and deep ionisation chamber for HIRA spectrometer.

### Electron beam welding machine

K. K. Mistry, G. K. Chaudhari and P. N. Prakash

- Electron beam welding machine is used for welding of the Niobium parts of Quarter Wave Resonators, mechanical tuners which are needed for the Superconducting Linear Accelerator of IUAC. This year most of the Niobium welding of the spare resonators and their frequency tuners were accomplished.
- EBW of Multi cell Niobium cavity of VECC was also carried out at IUAC as a part of inter institution collaboration and remaining work of the same project is also being done at regular intervals.

#### 3.2.3.2 Elevator and cranes

S. K. Saini, B. B. Choudhary and G. K. Chaudhari

- Kone Lift: Regular servicing is being done by authorized service person of KONE, and license of KONE lift was renewed.
- EOT Cranes/ Hoist: All EOT cranes are repaired and serviced regularly, all the breakdowns were attended and the maintenance was carried out.
- Hydraulic Trolleys/ pallet trolley are being maintained.
- Shifting of Heavy Scientific Machinery is being done as and when required. The equipment such as research instruments of Free Electron Laser, Materials science, MRI machine, Radiation shielding concrete blocks, etc. were loaded/unloaded/transported.
- Issue and upkeep, purchase, distribution and maintenance of industrial and specialty gas cylinders, maintenance of regulators, etc. were performed periodically.

#### 3.2.3.3 Fire fighting equipment

T. Varughese and D. K. Prabhakar

- Renewal of fire safety license of IUAC main building, and the auditorium was done.
- Audit and refilling of 320nos of portable fire extinguishers was carried out.

#### 3.2.3.4 Training

IUAC workshop is also providing Apprentice Training to the ITI trained manpower, graduate engineers both in machine shop and in welding shop.

All newly joined Scientists, Engineers and Junior Engineers were provided the basic training in the mechanical workshop for duration of two weeks by Sh. Thomas Verughese and Sh. K. K. Mistry. The purpose of training was to provide them some hands on experience at IUAC workshop and make them aware of shop floor practices.

### 3.2.4 Civil engineering department

Harshwardhan, Raj Kumar, Sourabh and D. S. Gangwar

IUAC campus is situated on a total plot area of 25 acre with built-up area (or ground coverage) of approximately 15000 m<sup>2</sup>. The total covered area of all floors is around 25000 m<sup>2</sup>. Centre has an academic or laboratory complex, utility buildings, auditorium, housing complex, hostel and guesthouse complexes. The civil engineering department takes care of day-to-day maintenance of all buildings, roads, sewerage system in campus including modifications, up-gradation, new construction activities and liaising with external agencies such as DDA, SDMC, Delhi Fire Service, Forest Department, RMB etc. for various statutory requirements

### 3. RESEARCH SUPPORT FACILITIES

---

such as building plan and construction approvals, fire safety approvals, property tax related issues etc.

The following are some of the important civil works undertaken through CPWD under deposit work mode:

- Up-gradation / renovation of Hostel complex, Main Gate House: The renovation work is in progress.
- Renovation work of UPS room and toilets has been taken up and is in progress.
- Construction of 8 Nos. Type-V (Kalptaru type) flats (proposal under process)
- Construction of New Lab Complex (proposal under process)

Following works have been carried out and completed directly by IUAC:

- Annual Contract for Day to day Up-keep and Maintenance of Civil Works at IUAC (Renewed for one year)
- Civil Work for setting up of 3PF Data Center and Hydraulic Lift
- Providing and Erection of fountain made out of natural Red Sandstone
- Annual rate contract for internal painting of vacant residential flats, office spaces in IUAC.
- Wall Mounted wooden almirah/Wall mounted Storage rack for Room No. 220,206, 207, 218 and Kamdhenu-17.
- Re-painting of Various Residential Flats after 5years maintenance period (11Nos.)
- P/F ACP cladding/Curtain wall on front facade of MS pipe/cable bridge adjoining to front side wall of Material Science (HPC) building, IUAC.
- Replacement of Indian type toilet seat (IWC) into European type toilet seat (EWC) including floor tiles at Flatlet II/3
- Cons of Badminton Court and partial covering of GI chain Link of existing badminton court
- Miscellaneous civil work in IUAC campus